

# **EXHIBIT 20**

**Chloride Reduction  
Implementation Plan**  
for  
**Dinsmore Brook Watershed**  
WINDHAM, NH



**February 2011**

**Chloride Reduction Implementation Plan**  
**for**  
**Dinsmore Brook Watershed**  
**Windham, NH**

Prepared by  
NH Department of Environmental Services  
Watershed Management Bureau

February 2011

Thomas S. Burack, Commissioner  
Harry T. Stewart, P.E., Director, Water Division

NH Department of Environmental Services  
29 Hazen Drive  
PO Box 95  
Concord, NH 03302-0095  
603-271-3503  
[www.des.nh.gov](http://www.des.nh.gov)

# Table of Contents

Section 1. Introduction and Background .....	6
Section 2. Watershed Information .....	7
2.1 Paved Surface Inventory .....	8
2.2. Winter Road Maintenance Policies in the Dinsmore Brook Watershed....	8
Section 3. Regulatory Authority and Enforcement.....	8
3.1. Federal Regulatory Authority .....	8
3.2. State Regulatory Authority .....	8
3.3. Regulatory Framework Applicable to Dinsmore Brook.....	8
3.4. Water Quality Monitoring and Violations .....	8
Section 4. Salt Allocations and Use.....	8
4.1. Sector Allocations.....	8
4.2. Review of Salt Use in Dinsmore Brook.....	8
4.3. Identification of Key Issues with Salt Use.....	8
Section 5. Chloride Reduction Best Management Practices (BMPs) and Achievability ...	8
5.1 Readiness: Preparing Operations .....	8
5.1.1 Recordkeeping and Salt Accounting Systems .....	8
5.1.2 Training.....	8
5.1.3 Equipment.....	8
5.1.4 Calibration .....	8
5.1.5 Storage and Site Management .....	8
5.2 Information: Evaluate and Monitor Conditions.....	8
5.2.1 Weather Information Resources: .....	8
5.2.2 Pavement Temperature .....	8
5.2.3 Traffic, Road Surface, Beat .....	8
5.3 Decision: Treatment Technique and Selection of Material .....	8
5.3.1 Treatment Techniques: Plow, Anti-Ice, De-ice .....	8
5.3.2 Selection and Use of Materials.....	8
5.4 Action: Application Rates and Practices.....	8
5.4.1 Sidewalk Treatment.....	8
5.4.2 Calculating the Area of a Parking Lot or Sidewalk.....	8
5.5 Evaluate: Review of Activities for Subsequent Operations.....	8
5.6 Estimated Percent Chloride Reduction Potential by BMP Type .....	8
Section 6. Additional Recommendations for Chloride Reduction.....	8
6.1 Procedural/Operational Training Programs .....	8
6.2 Revisions to Planning and Site Plan Review Process.....	8
6.3 Liability Protection from Slip and Fall Claims.....	8
6.4 Addressing Driver Behavior and Expectations.....	8
Section 7. Implementation Schedule & Assessment of Progress .....	8

Section 8. References.....	8
Section 9: Appendices.....	8

- Appendix A: State of NHDOT Winter Maintenance Storm Log
- Appendix B: UNH Technology Transfer Center Hydraulic-Run Calibration
- Appendix C: UNH Technology Transfer Center Pony-Run Spreader Calibration
- Appendix D: NHDES Holding Tanks for Floor Drains
- Appendix E: UNH Technology Transfer Center Anit-Icing
- Appendix F: How Salt Works - UNH Technology Transfer Center and NHDES  
Fact Sheet Road Salt and Water Quality
- Appendix G: UNH Technology Transfer Center Brine
- Appendix H: UNH Technology Transfer Center Pre-Wetting
- Appendix I: NHDES Storage & Management of Salt Deicing Materials
- Appendix J: NYSDOT Application Rate Guidelines for Roads
- Appendix K: UNH Application Rate Guidelines for Parking Lots
- Appendix L: NHDES Wastewater Discharges from Vehicle Washing
- Appendix M: Hamilton NJ Application Guidelines for Salt Brine (23.3%)

### **List of Figures**

- Figure 1. Dinsmore Brook Watershed Map
- Figure 2. Dinsmore Brook Watershed Roads and Parking Lots Map
- Figure 3. Relative Contribution of Each Source to the Total Salt Imports to the Watershed
- Figure 4. Salt Imports versus Weather Severity Index
- Figure 5. Hand Held Pavement Sensor: photo credit: MN Parking Lot Manual
- Figure 6: Down-Pressure Plow, photo credit: Iowa DOT Aug 2010
- Figure 7: Moldboard Plow Designs, photo credit: Iowa DOT Aug 2010
- Figure 8: Underbody Plow, photo credit: Iowa DOT Aug 2010
- Figure 9: Underbody Plow with Mid-mount Wing Single-Axle, photo credit: Iowa DOT  
Aug 2010
- Figure 10: Underbody Plow with Mid Mount Wing Tandem-Axle, photo credit: Iowa DOT  
Aug 2010
- Figure 11: Dual Mount Wings Single Axle, photo credit: Iowa DOT Aug 2010
- Figure 12: Flexible/Segmented Cutting Edge, photo credit: Iowa DOT Aug 2010
- Figure 13: Razor Blade Edge Set-Up, photo credit: Iowa DOT Aug 2010
- Figure 14: Slush Blade Version 1, photo credit: Iowa DOT Aug 2010
- Figure 15: Slush Blade/Cutting Edge Engaged, photo credit: Iowa DOT Aug 2010
- Figure 16: Multiple Blade, graphic credit: Iowa DOT Aug 2010
- Figure 17: Operator Controls, photo credit: [www.UCDavis.edu](http://www.UCDavis.edu)
- Figure 18: Slide in Spreader, photo credit NH DOT
- Figure 19: Zero Velocity Spreader, photo credit: Nantung 2001
- Figure 20: Tailgate Mounted Pre-Wet Unit, photo credit: North Dakota DOT Fact Sheet
- Figure 21: Integrated Tailgate Pre-Wet Unit, photo credit: Iowa DOT
- Figure 22: Liquid Anti-Icing Spray Bar, photo credit: UNH T2 Road Business 2007

Figure 23: Tow Behind Liquid Anti-Icing, photo credit: North Dakota DOT Fact Sheet  
Figure 24: Slip-In Anti-Icing Brine Unit, photo credit: Iowa DOT  
Figure 25: Slip-In Brine Unit, graphic credit: Iowa DOT  
Figure 26: Snow and Salt Storage, photo credit: MN Parking Lot Manual  
Figure 27: Town of Derry NH Salt Shed, photo credit: Ricci Construction  
Figure 28: Brine Storage Tanks, photo credit Hamilton NJ 2007  
Figure 29: Stow Storage and Disposal, photo credit: [www.CAMColorado.com](http://www.CAMColorado.com)  
Figure 30: RWIS station, photo credit: NH DOT  
Figure 31: Anti-Icing / De-Icing, photo credit: North Dakota DOT Fact Sheet  
Figure 32: Pounds of Ice Melted per Pound of Salt, graphic credit: Salt Institute Snow and Ice Fact Sheet #22  
Figure 33: Brine Making, photo credit Iowa DOT  
Figure 34: Phase Diagram for Salt, photo credit: The Salt Institute  
Figure 35: Salometer, photo credit: UNH T2 Winter 2007  
Figure 36: Salt Melting Dry vs. Pre-Wet, photo credit: Wisconsin DOT bulletin #22  
Figure 37: Bounce and Scatter of Salt, graphic credit: Michigan Highway Department  
Figure 38: Overhead Pre-Wet Sprayer, photo credit: Hamilton NJ 2007  
Figure 39: Sand Clean-Up, photo credit: Town of Whitestown NY  
Figure 40: Sidewalk Salt Spreader, photo credit [tactorbynet.com](http://tactorbynet.com)  
Figure 41: Vegetation Damage by a Sidewalk, photo credit: [www.forestryimages.com](http://www.forestryimages.com)  
Figure 42: Message Board Posting, photo credit: NH DES bulletin posting

## **List of Tables**

Table 1. Dinsmore Brook Watershed Paved Surface Inventory  
Table 2. Periods in violation of the chronic water quality standards for 7/1/07-6/30/08  
Table 3. Periods in violation of the chronic water quality standards for 7/1/08-6/30/09  
Table 4. Periods in violation of the chronic water quality standards for 7/1/09-6/30/10  
Table 5. TMDL Salt Imports and Load Allocations  
Table 6. Dinsmore Brook 10-Year Salt Use Comparison to TMDL Values  
Table 7. Generalized Environmental Concerns for Chloride Alternatives  
Table 8. General Application Rates  
Table 9. Recommended Chloride BMPs  
Table 10. Dinsmore Brook Chloride TMDL Implementation Schedule  
Table 11. Chloride Reduction Implementation Plan Matrix

## **Section 1. Introduction and Background**

Dinsmore Brook is designated as an impaired water by the New Hampshire Department of Environmental Services (DES) for chloride levels that exceed water quality standards during various times of the year. A Total Maximum Daily Load study (TMDL), completed in 2008 (NHDES, 2008), determined that the chloride load to the watershed is primarily the result of salt application for winter road and parking lot maintenance from the state (50% of the salt load), municipal (2%), and private (47%) sectors.

The goal of this Total Maximum Daily Load implementation plan is to provide recommendations for achieving chloride load reductions within Dinsmore Brook watershed that will result in the brook meeting chloride water quality standards. The various owners of roads and parking lots to which salt is applied are jointly responsible for meeting the TMDL load reductions in order to meet water quality standards. It is DES's intention to work with the various sectors to achieve load reductions, prior to any enforcement actions being taken. However, if needed, DES can use authority in state law (RSA 485-A:12, Enforcement of Classification) to implement the plan as necessary or can defer to EPA to use its NPDES permit authority to enforce control of stormwater runoff.

The NH Department of Transportation (DOT) plans to expand I-93 to a four-lane highway in either direction. DOT's permit requires that salt use must not exceed the load allocations set within the TMDL. Implementation of TMDL reductions and respective salt allocations are expected to result in compliance with water quality standards. If load reductions cannot be met, DOT cannot pave and operate the fourth lane of the expanded highway in either direction.

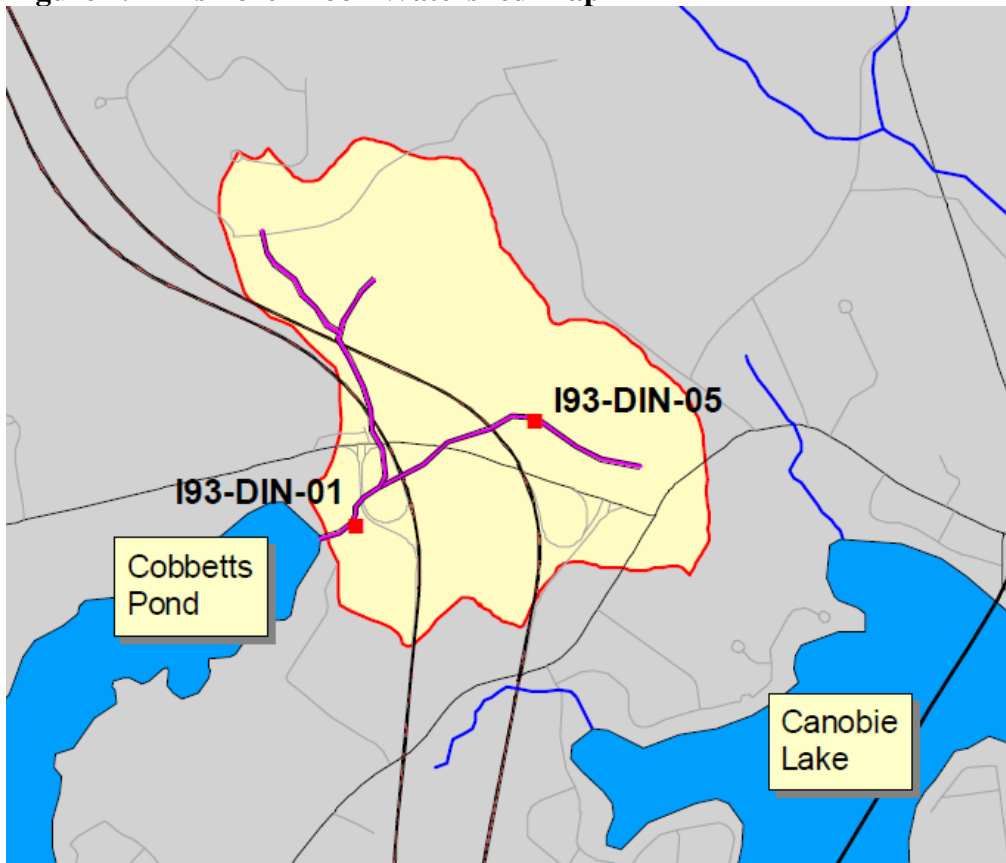
Public safety and potential liability are at the forefront of concerns when dealing with chloride reduction efforts. This plan uses an integrated management approach with a framework that provides recommendations for various state and municipal agencies, road and parking lot maintainers and the general driving public.

Innovative techniques for chloride reduction efforts will continue to develop over time; therefore this implementation plan should be reviewed and modified every five years until the chloride water quality standards in Dinsmore Brook are met.

## **Section 2. Watershed Information**

Dinsmore Brook is a 1.5 mile stream segment (0.55 square mile drainage area) in Windham, N.H., classified as a Class B waterbody (see Figure 1). According to Env-Ws 1703.21, the water quality criteria for chloride in nontidal Class B waterbodies to protect aquatic life are 860 mg/L for acute exposures and 230 mg/L for chronic exposures. Acute aquatic life criteria are based on an average concentration over a one-hour period and chronic criteria are based on an average concentration over a four-day period. The frequency of violations for either acute or chronic criteria should not be more than once every three years, on average (EPA, 1991).

**Figure 1. Dinsmore Brook Watershed Map**





## 2.1 Paved Surface Inventory

The TMDL states that approximately 29 percent of the Dinsmore Brook watershed is classified by the U.S. Census as “urbanized area.” Table 1 and Figure 2 show the state, municipal and private roads and parking lots in the watershed.

**Table 1. Dinsmore Brook Watershed Paved Surface Inventory**

Sector	Unit
NH Department of Transportation	6.5 Lane Miles*
NH Department of Transportation	9.8 Lane Miles**
Town of Windham	1.0 Lane Miles
Private Roads	4.2 Lane Miles
Private Parking Lots	7.5 Acres
Private Parking Lot Driveways	0.7 Lane Miles

\* Lane miles maintained upon TMDL completion

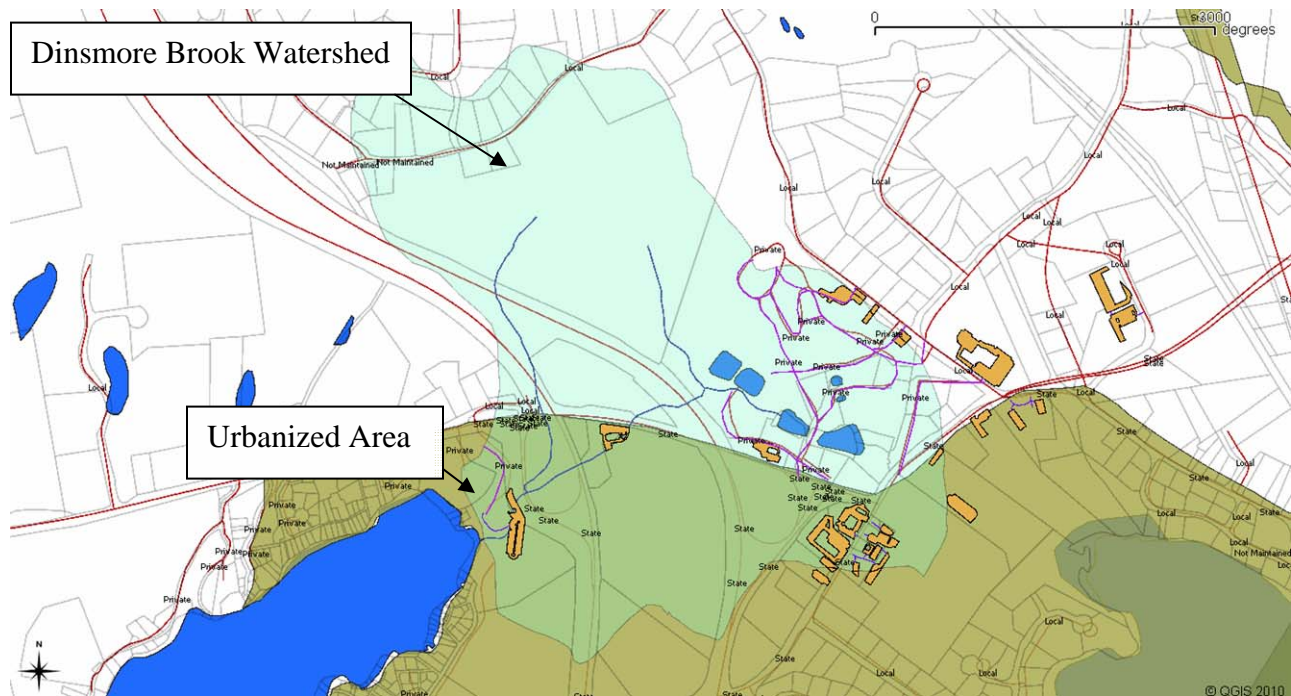
\*\* Estimated lane miles to be maintained after I-93 expansion

DOT is currently responsible for winter maintenance on 6.5 total lane-miles within the watershed. As a result of the I-93 expansion, it is estimated that DOT will maintain 9.8 lane miles within the Dinsmore Brook watershed.

According to the town of Windham’s Salt Reduction Plan (2010) the town is responsible for winter maintenance on 1.0 lane miles of road within the watershed. There are no municipally maintained parking lots within the watershed.

Existing private roads and parking lots are accounted for in the TMDL inventory. Within the watershed there are 4.2 lane miles of private roads, 7.5 acres of parking lots, and 0.7 lane miles of parking lot driveways. Population growth is expected in the future as a result of the I-93 expansion. Growth will increase the use of chloride deicing chemicals. The TMDL did not include any allocation for future development. An allowance for increased use of salt due to additional development including roads and parking lots can be included in future implementation plans if there is an explicit offset of salt import for winter maintenance obtained from other sources in the watershed.

**Figure 2. Dinsmore Brook Watershed Roads and Parking Lots Map**



## **2.2. Winter Road Maintenance Policies in the Dinsmore Brook Watershed**

- New Hampshire Department of Transportation  
The following documents reflect DOT policies on snow and ice management in New Hampshire.

*Winter Maintenance Snow Removal and Ice Control Policy, October 15, 2001.* The level of service and operating procedures to maintain state roadways are defined but environmentally sensitive areas or anti-icing and/or other best management practices are not discussed.

*Implementation Plan to Increase the Efficiency and Effectiveness of Road Salt Use To Meet Total Maximum Daily Load For Chloride in Water bodies Along the I-93 Corridor from Salem to Manchester, September 2009.* This plan accounts for road salt needs and the estimated achievable chloride reductions within Dinsmore Brook that are associated with existing state highways, municipal roads, and the proposed widening along the I-93. The plan includes best management practices which in combination with each other are estimated to achieve a 20 percent chloride reduction. Since a 20 percent reduction will not meet water quality standards, additional chloride reductions are needed unless other sectors are able to take on a larger

portion of the salt reduction given the mitigating factors including safety, level of service and use.

- Town of Windham

The town of Windham has taken the following steps to reduce chloride loading since the issuance of the TMDL:

*A Salt Reduction Resolution* was signed on April 6, 2009 that commits the town to work with the other sectors on salt reduction in the impaired watersheds.

*A Salt Reduction Plan* was completed in August 2010. The plan incorporates some best management practices as well as a pilot program. The plan estimates that the town of Windham will obtain a 0.55 ton/year reduction in salt applied within the Dinsmore Brook watershed in the first year of plan implementation. The anticipated reduction is not adequate to meet the TMDL, however it is understood that the salt reduction plan will be revised each year to incorporate changes to winter maintenance strategies that will achieve additional reductions.

Winter maintenance training is conducted yearly with municipal staff and hired drivers. Training focuses on calibration of equipment.

- Private Sector Owners and Maintainers

The parking lot and private driveway owners and/or maintainers typically do not have snow and ice removal policies. Each parking lot or road is managed differently, based on the property owner's objectives. Currently there is no commitment from private parking lot owners or maintainers to reduce salt used in impaired watersheds; however, some private snow and ice removal companies that are contracted to service areas within Dinsmore Brook watershed have attended training and are willing to tell their clients about salt reduction efforts.

## **Section 3. Regulatory Authority and Enforcement**

### **3.1. Federal Regulatory Authority**

The United State Environmental Protection Agency (EPA) regulates stormwater through the National Pollutant Discharge Elimination System (NPDES) program, which is authorized by the Clean Water Act. The NPDES program requires permitting of stormwater discharges from separate municipal storm sewer systems (MS4s) in urbanized areas and from industrial and construction activities. Twenty nine percent of the Dinsmore Brook watershed is covered by the MS4 program.

EPA has residual designation authority under Section 402(p)(2)(E) of the Act to designate pollution sources for issuance of individual stormwater permits in order to achieve compliance with water quality standards.

Section 303(d) (1) (c) of the Act provides that Total Maximum Daily Load (TMDL) studies must be completed when a water body is not meeting water quality standards. The TMDL must identify the amount of pollutant(s) allowable in order to meet the state water quality standard.

Section 401 of the Act requires that the state water quality agency (DES) certify that any federally permitted activity which may result in a discharge will not violate water quality standards. A 401 water quality certificate can contain conditions and monitoring requirements to insure that the permitted activity will meet the load reductions in the TMDL.

### **3.2. State Regulatory Authority**

RSA 485-A:12.II provides that “If, after adoption of a classification of any stream, lake, pond, or tidal water, or section of such water, including those classified by RSA 485-A:11, it is found that there is a source or sources of pollution which lower the quality of the waters in question below the minimum requirements of the classification so established, the person or persons responsible for the discharging of such pollution shall be required to abate such pollution within a time to be fixed by the department ....”

State law also grants municipalities the authority to regulate “the collection, removal and destruction of garbage, snow and other waste materials” under RSA 39:31.I (f). The “removal and destruction of snow” includes practices that utilize chlorides and other deicing agents. Additionally, RSA 149-I:1 authorizes municipalities to adopt bylaws addressing stormwater if they have adopted stormwater utilities.

Existing and new salt storage facilities that are located or operate on a permeable surface, or that infiltrate brine from runoff to the ground or groundwater need to

register with DES under the Groundwater Discharge Permit and Registration Rules, Env-Wq 402. This is a free registration and is a method of tracking potential contaminant sources. If there are sensitive receptors nearby, some sites may be required to monitor drinking water wells and/or the groundwater. The registration form can be found at:

[http://des.nh.gov/organization/divisions/water/dwgb/dwspp/bmps/documents/floor\\_drain\\_form.pdf](http://des.nh.gov/organization/divisions/water/dwgb/dwspp/bmps/documents/floor_drain_form.pdf).

### **3.3. Regulatory Framework Applicable to Dinsmore Brook**

The 401 Water Quality Certificate issued May 2, 2006 by DES to DOT for the I-93 widening project states:

After EPA approval of the TMDL reports and publication of the TMDL implementation plan, the Applicant shall implement the chloride load reductions and all other requirements of the implementation plan that apply to the Activity and to other state roads included in the implementation plans.

The water quality certificate also requires that if the TMDL load reductions are not met, that DOT shall incrementally implement the project by paving and operating only three lanes in each direction until there is full implementation of the TMDLs for state roads in the impaired watersheds.

A Memorandum of Agreement between DES and DOT executed on June 21, 2006 further defines that “full implementation of chloride load reductions means load reductions have already been achieved.”

Actual allowed salt use will be adjusted for annual weather conditions by the Weather Severity Index (WSI), which shows a correlation between salt use and weather severity with greater than 95 percent confidence. A rolling ten-year average of WSI-adjusted salt use will be used to determine compliance with the TMDL.

### **3.4. Water Quality Monitoring and Violations**

In the Memorandum of Agreement with DOT, DES committed to monitoring chloride concentrations in the impaired watersheds through 2016 to measure progress toward meeting the TMDLs. The sampling design for TMDL Implementation Monitoring includes year-round data collection at one station in the Dinsmore Brook watershed (I93-DIN-01). Dataloggers are used to measure specific conductance and temperature at 15 minute intervals throughout the year. During station visits every six weeks, DES collects grab samples for chloride (measured using an ion-specific probe in the DES Limnology Center), measures specific conductance and temperature with an independently calibrated meter, and services the dataloggers. One field duplicate sample for chloride and one field

duplicate measurement for temperature and specific conductance are collected each sampling day.

DES will be responsible for ensuring that data meet the Quality Assurance Project Plan requirements and will prepare documentation that includes the data submittal, any non-conformances, and data that did not pass the QC requirements. Data quality audits will be performed annually in the fall with trend analysis reports in the fall of 2011 and 2016.

From 2007 to 2010, since the publication of the TMDL, the chronic criteria for chloride was exceeded in Dismore Brook for a total of 122.61 days, as shown in Tables 2 through 4 below.

**Table 2. Periods in violation of the chronic water quality standards for 7/1/07-6/30/08**

Station	Violation Episode	Start Time	End Time	Duration (days)	Number of Violations	Total Violation (days)
I93- DIN-01	1	7/24/2007 10:30	10/1/2007 8:45	68.93	17	81.4 days
	2	12/25/2007 20:45	1/7/2008 8:30	12.49	3	

*FY 08 TMDL Implementation Monitoring Data Report and Quality Assurance Audit*

**Table 3. Periods in violation of the chronic water quality standards for 7/1/08-6/30/09**

Station	Violation Episode	Start Time	End Time	Duration (days)	Number of Violations	Total Violations (days)
I93- DIN-01	1	7/13/2008 18:00	7/21/2008 16:45	7.95	2	14.51 days
	2	8/31/2008 11:30	9/7/2008 1:00	6.56	2	

*FY 09 TMDL Implementation Monitoring Data Report and Quality Assurance Audit*

**Table 4. Periods in violation of the chronic water quality standards for 7/1/09-6/30/10**

Station	Violation Episode	Start Time	End Time	Duration (days)	Number of Violations	Total Violations (days)
I93- DIN-01	1	9/4/2009 12:30	9/11/2009 23:45	7.47	2	26.7 days
	2	9/13/2009 3:45	9/18/2009 23:00	5.8	1	
	3	9/20/2009 9:00	9/29/2009 6:30	8.9	2	
	4	9/29/2009 7:45	10/3/2009 20:30	4.53	1	

*FY 2010 TMDL Implementation Monitoring Data Report and Quality Assurance Audit*

For full data reports please refer to the following web links:

[www.des.nh.gov/organization/divisions/water/wmb/tmdl/documents/chloride\\_data\\_report.pdf](http://www.des.nh.gov/organization/divisions/water/wmb/tmdl/documents/chloride_data_report.pdf)

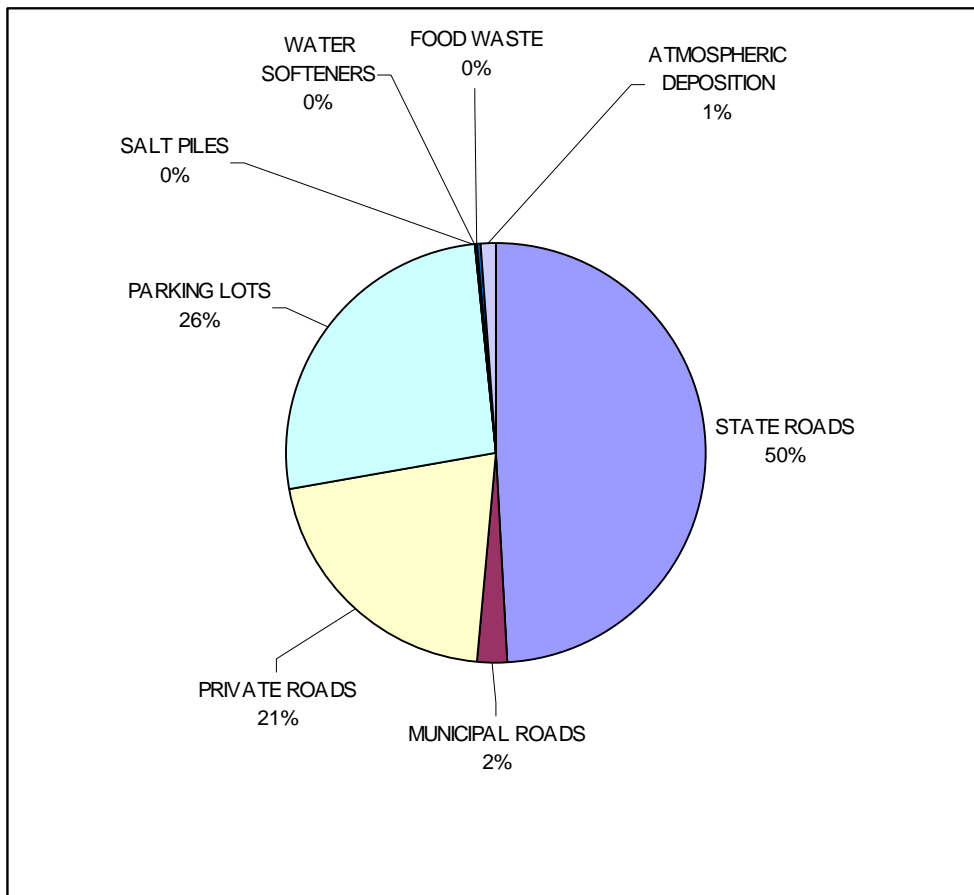
[www.rebuildingi93.com/documents/environmental/Dinsmore\\_Brook\\_TMDL\\_2008.pdf](http://www.rebuildingi93.com/documents/environmental/Dinsmore_Brook_TMDL_2008.pdf)

## Section 4. Salt Allocations and Use

### 4.1. Sector Allocations

Figure 3 shows the relative contribution of each source to the total salt imports for the Dinsmore Brook watershed. Fifty percent of the salt is from DOT-maintained roads ('the state sector'), 2 percent is from Windham roads ("the town sector"), and 47 percent is from private roads, driveways, and parking lots ("the private sector").

**Figure 3. Relative Contribution of Each Source to the Total Salt Imports to the Watershed**



The TMDL concludes that to meet water quality criteria, annual salt imports to the watershed should be no more than 126.0 tons, of which 123.1 tons would be from winter road maintenance. It should be noted that this amount does not account for future development, therefore any new development of roads or parking lots would necessitate additional load reductions elsewhere in the watershed.

The approved TMDL authorizes the Salt Reduction Work Group, made up of representatives from each sector, to negotiate and approve alternate sector

allocations if desired, provided that overall imports do not exceed 126.0 tons/salt/year.

The starting point for sector negotiations was the “equally shared reduction” scenario presented in the approved TMDL. The Dinsmore Brook sector allocation meeting took place on July 28, 2010, where agreement on a revised sector allocation was reached, and later ratified by the Salt Reduction Work Group.

Table 5 compares the revised sector allocations to the 2008 TMDL allocations. The allocation values for the private roads and parking lots were changed to more accurately reflect the amount of salt being applied to the private roads and parking lots. Many of the private road miles service communities whose associations contract for winter maintenance. Contractors offer a lower price for service without salting, since plowing can be accomplished with a smaller, more economical vehicle. Also, two of the private parking lots were eliminated due to the reconfiguration of Exit 3. The DOT allocation was increased commensurate with the decreases in private sector allocations.

**Table 5. TMDL Salt Imports and Load Allocations**

Source	Agency/ Town	FY07 Salt Imports (tons salt/yr)	2008 TMDL Equally Shared Reduction Scenario Allocation of Loads (tons salt/yr)	2010 Revised Reduction Scenario Allocation of Loads (tons salt/yr)
State Roads	NHDOT PS 514	24.7	18.6	27.5
	NHDOT PS 528	57.0	42.9	63.5
Municipal Roads	Windham	4.0	3.0	3.0
Private Roads	Windham	34.3	25.8	10
Parking Lots	Windham	43.4	32.7	22
Salt Piles	Windham	0.0	0.0	0.0
Water Softeners	NA	0.7	0.7	0.7
Food Waste	NA	0.5	0.5	0.5
Atmospheric Deposition	NA	1.7	1.7	1.7
Total		166.5	126.0	126.0

*Source: April 2008 Total Maximum Daily Load Study; Dinsmore Brook*



After more experience has been gained by conducting pilot programs, incorporating BMPs and educational outreach and training initiatives in the next five years, the Salt Reduction Work Group should reevaluate the sector allocations along with increased salt application caused by new growth.

## 4.2. Review of Salt Use in Dinsmore Brook

The Salt Reduction Workgroup requested that DES calculate the salt use for the past 10 years (FY 2001- FY 2010) using salt use data from both pre and post TMDL issuance; which allows for a time series evaluation. The data shows the trend of salt loading over time versus the Weather Severity Index (WSI).

The analysis for Dinsmore Brook contained in Table 6 shows that large reductions of salt imports are needed in the watershed. The ten year average salt import rate is 245 tons/year. Based on the ten years of existing data, a reduction of 49 percent is needed to reach the TMDL target of 126 tons/year.

**Table 6: Dinsmore Brook 10-Year Salt Use Comparison to TMDL Values**

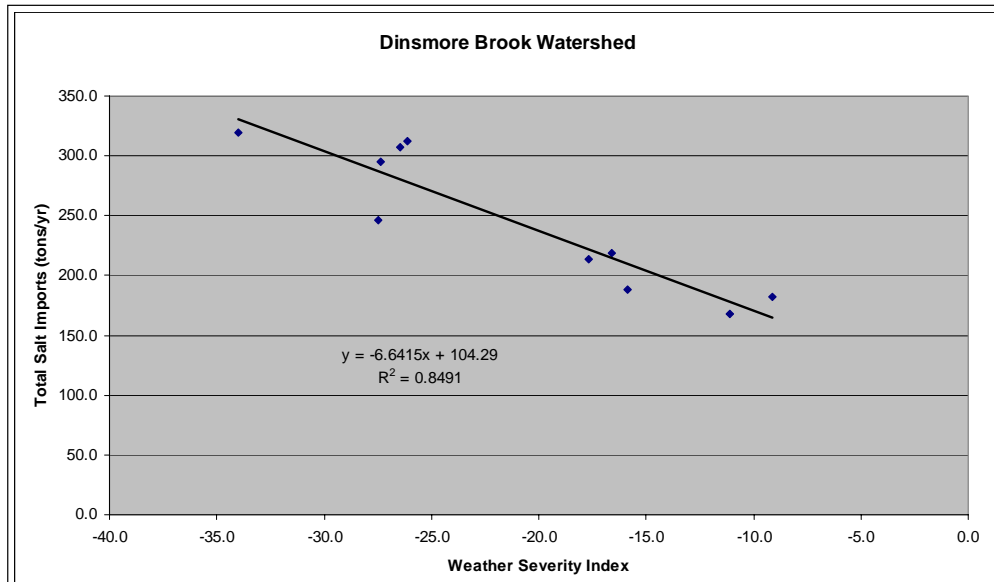
Watershed Characteristics	Watershed Salt Imports (tons of salt per year)												Revised TMDL Allocation tons/yr
	FY01	FY02	FY03	FY04	FY05	FY06	TMDL year FY07	FY08	FY09	FY10	10-yr Avg. tons/yr	FY08-FY10 Avg. tons/yr	
STATE ROADS													
NHDOT Patrol Shed 514	42.4	19.9	54.2	28.0	56.2	30.2	24.7	47.4	35.4	24.7	36.3	35.8	27.5
NHDOT Patrol Shed 528	120.5	68.3	114.7	87.5	116.7	69.6	57.0	125.2	92.9	67.8	92.0	95.3	63.5
MUNICIPAL ROADS- Town of Windham	4.2	3.4	5.7	4.5	5.5	4.3	4.1	4.3	3.3	3.1	4.2	3.6	3
PRIVATE ROADS- Town of Windham	53.3	43.9	55.1	44.3	55.1	52.0	35.3	56.1	50.5	41.0	48.7	49.2	10
PARKING LOTS- Town of Windham	72.0	43.2	74.7	51.7	75.4	54.8	43.4	83.2	60.7	48.7	60.8	64.2	22
SALT PILES- Town of Windham	0.0	0.0	0.0	0.0	0.0	0.0	0.0	0.0	0.0	0.0	0.0	0.0	0.0
ATMOSPHERIC DEPOSITION	1.7	1.7	1.7	1.7	1.7	1.7	1.7	1.7	1.7	1.7	1.7	1.7	1.7
DOMESTIC WASTE	0.5	0.5	0.5	0.5	0.5	0.5	0.5	0.5	0.5	0.5	0.5	0.5	0.5
WATER SOFTENERS	0.7	0.7	0.7	0.7	0.7	0.7	0.7	0.7	0.7	0.7	0.7	0.7	0.7
<b>TOTAL</b>	<b>295.5</b>	<b>181.6</b>	<b>307.5</b>	<b>218.8</b>	<b>311.9</b>	<b>213.9</b>	<b>167.5</b>	<b>319.2</b>	<b>245.8</b>	<b>188.3</b>	<b>245.0</b>	<b>251.1</b>	<b>126.0</b>
WSI	-27.4	-9.1	-26.5	-16.6	-26.1	-17.7	-11.1	-34.0	-27.5	-15.9	-21.2		
WSI relative deviation from 10-yr average	0.29	-0.57	0.25	-0.22	0.23	-0.17	-0.48	0.61	0.30	-0.25			
<b>TMDL (WSI adjusted)</b>	<b>162.9</b>	<b>54.4</b>	<b>157.5</b>	<b>98.8</b>	<b>155.2</b>	<b>105.1</b>	<b>66.1</b>	<b>202.3</b>	<b>163.4</b>	<b>94.4</b>	<b>126.0</b>		

*Some values in this table are different from those published in the TMDL. The differences are due to new salt application rates provided by towns.*

The WSI takes into consideration multiple winter weather conditions, such as snowfall amounts, total storm hours, air temperatures, and heating degree-days that would encompass the relative severity of the winter season. Salt imports to the Dinsmore Brook Watershed were highly correlated to the WSI (r2 value = 0.8491),

as seen in Figure 4, indicating that allowable thresholds of annual salt use can be tied to the WSI.

Figure 4. Salt Imports versus Weather Severity Index



### 4.3. Identification of Key Issues with Salt Use

In order to understand how to manage chlorides efficiently and effectively it is important to first identify why and how chlorides are over-applied to roadways and parking lots. The over-application of road salt is primarily a function of the following five key issues:

#### Key Issue #1:

#### Not knowing that certain conditions may not warrant salt application

Certain situations that may not warrant application of road salt are most commonly categorized in two ways:

- Times when pavement temperatures and other temperatures are warm enough or rising to suggest that snow and ice will not accumulate on the road or parking lot.
- Extreme cold and/or windy conditions. Road salt becomes less effective as temperatures drop. Review of literature suggests that application of road salt at 15° F is not recommended because it could cause brief melting and re-freeze. This can create icy conditions whereas if no chemicals were applied snow could blow off or be mechanically removed with a plow.

**Key Issue #2:**

**Not knowing and/or tracking how much material is being applied**

Knowing how much deicing material that is being applied by equipment is critical to every winter maintenance program. It is important to understand that each truck or piece of equipment can apply different amounts of deicer. Variations in spinner speed, RPMs, spinner throw distance and/or patterns, and belt speed can affect and vary the amount of salt being applied.

It is important for the operators of each truck to know their equipment capabilities and identify any issues. Knowing staff and their habits also is an important component of managing the amount of salt applied.

Because most municipalities and the DOT already track salt use, a salt accounting system is being developed for the private sector by the University of New Hampshire, Technology Transfer Center.

**Key Issue #3:**

**Not knowing how much material is needed to achieve desired results**

It is important to educate managers and drivers on how much material is needed to obtain the desired level of service results. Gaining an understanding of how deicers properly work with various weather conditions and pavement temperatures is key to reducing the amount of salt applied.

Experimentation with application rates, beginning at current application rates and working gradually downward, is recommended. Determine application rates for achieving results without over applying. Record application rates and share your findings.

**Key Issue #4:**

**Over application of chlorides due to liability concerns**

Potential liability is at the forefront of concerns when dealing with snow and ice removal. Privately owned commercial parking lots and driveways contribute significant salt loading in impaired watersheds. A major obstacle voiced by private sector representatives is concern for increased liability due to salt reduction practices. In addition, the profession currently lacks formal training programs for snow and ice removal operators. Legislation is being developed which will provide liability protection through the creation of a certification and training program that will require salt use to be reported.

**Key Issue #5:**

**Decisions are made without knowledge of new technologies and practices**

Winter maintenance is complicated and training needs to be provided to all managers, supervisors, operational staff and hired contractors that deal directly with snow and ice management tasks. Training saves time and money, and increases morale, knowledge and safety. Training should be focused on types of snow and ice removal methods, types of materials, how much material is needed and the right place and right time for applications.

Understanding these five key issues in the application of road salt and employing ways to reduce the amount of salt being used will help in the reduction of chlorides in the Dismore Brook Watershed.

## **Section 5. Chloride Reduction Best Management Practices (BMPs) and Achievability**

This section discusses chloride reduction recommendations that are designed to maintain current safe levels of service while meeting the TMDL allocation. The chloride reduction achieved by each sector is dependent on many variables such as: degree of implementation, level of operational training, tracking salt use, equipment type used and proper equipment maintenance and calibration.

Adopting best management practices specified in this plan will require well-managed operations. Initially, equipment may need to be retrofitted and/or purchased to fully implement BMPs. It is understood that each sector has different operational budgets and equipment types; therefore the most practical BMPs have been chosen for this plan that will yield the greatest outcome in terms of salt reduction.

DES does not endorse any equipment manufacturers or proprietary products. It is each sector's responsibility to determine what specific equipment and product types they wish to include in their winter maintenance programs. DES is working towards creating a NH Salt Application Best Management Practice Manual. In the absence of the New Hampshire manual, salt applicators should follow recommendations contained within this implementation plan.

### **Benefits of Best Management Practices**

Improved Level of Service: A winter maintenance plan that is informative, knowledgeable and well executed results in consistent services to the public.

Improved Safety: A good understanding of materials, application rates, weather, and equipment minimizes dangerous road conditions.

Protect Water Quality: Understanding and implementing BMPs will reduce the amount of chloride in the impaired waters and help meet chloride reduction goals.

Save Money and Resources: Knowing how to use the right treatment at the right time will save time, money, and materials.

There are five main steps to effectively and efficiently manage chloride application in the Dinsmore Brook watershed. The following steps will assist with choosing approaches that reduce chloride application while increasing the level of service. It is important to

understand that combining existing experience with the use of best management practices is the key to having a more effective and efficient winter operation.

### **Steps to Achieve Best Management Practices**

Readiness – training, equipment, calibration, storage, accounting

Information - evaluate and monitor conditions

Decision – selection of material and treatment technique

Action – application rates and practices

Evaluation – review of activities for subsequent operations

## **5.1 Readiness: Preparing Operations**

The goal of operational readiness is to prepare facilities, crew, and equipment well in advance. Update policies to include any changes in roads, traffic, economics, mobility, environmental concerns and safety that may affect Level of Service.

### **5.1.1 Recordkeeping and Salt Accounting Systems**

Documentation is critical to the successful implementation of best management practices. Keeping records of all activities is needed for proper salt management and helps to manage liability exposure. Important areas of winter operations that should be documented include salt accounting, equipment calibration, training records, and storm logs that include weather, plowing activities, treatment time and location. Refer to Appendix A for the State of New Hampshire Department of Transportation Winter Maintenance Storm Log. Spreader Calibration log sheets can be found in Appendix E for hydraulic spreaders and Appendix F for pony motor spreaders.

It is critical in that all sectors track chloride use to measure progress toward meeting the TMDL.

#### Department of Transportation

The Department of Transportation has traditionally accounted for salt loading in the Dinsmore Brook watershed by calculating the amount of salt used from the salt shed inventory. Although the overall volume of salt applied was known, variations in application rates were not known. To address this concern, DOT received a grant to install global positioning systems (GPS) computer

controllers in several of their trucks. By using this system of data collection it automatically records where and how much salt is being applied. The department will be adding GPS equipment to their trucks over the next several years with hopes to have all trucks in the watershed equipped by 2013.

#### Town of Windham

Windham will continue to track salt application, in tons/road mile for routes within the watershed by maintaining accurate invoices, cancelled checks, and purchase orders. Windham will begin to monitor its salt use through new GPS tracking equipment and by using enhanced GIS software. This will provide accurate chloride imports in the Dinsmore watershed allowing for data to be monitored over the winter with analysis and reporting to be completed by spring. Windham estimates they will begin using GPS/GIS in 2011/2012. The town will report total salt use to DES at the end of each winter season.

#### Private Sector

Quantification of private sector chloride imports will be accomplished by a geospatial salt accounting system under development by UNH T2. The online system will allow private sector winter maintenance contractors to report annual salt usage and location data. It is critical that the system and the reporting criteria not present a burden to private sector operations or profitability. Optional functionality will allow users, for their own benefit, to track operations by storm event.

### **5.1.2 Training**

Altering the approach to winter operations will require training and changes in knowledge and behavior of road managers, supervisors, and operators. Training should be centered on the balance between environmental awareness and level of service to the public.

Training should be presented in the following areas:

- Interpretation of weather and pavement conditions when making decisions.
- Best management practices, including how to correctly calibrate equipment.
- Location of and treatment in environmentally sensitive areas.
- When and how to apply chemicals.
- Use of liquid chemicals for pre-wetting and anti-icing.
- Record keeping.

The DOT goal is to train field crews in winter maintenance operations annually. Currently all employees receive eight hours of classroom training to review snow and ice control procedures. DOT also offers this course to the private contractors that assist in winter operations. Employees are provided additional opportunities to attend courses presented by UNH T2.

The town of Windham has committed to ongoing winter maintenance staff training and education. The town requires that all staff attend salt reduction training and requests that private sector contractors hired by the town attend as well.

UNH T2 provides workshops, newsletters, technical assistance, a Road Scholar Program, and links to additional on-line information at [www.t2.unh.edu](http://www.t2.unh.edu). Training is available to state, municipal, and private sector applicators and staff. Certificates are provided to those who attend training courses.

It is recommended that a training log be kept, including the trainer and trainee's names and the date so periodic refresher courses can be provided to update staff on new technologies.

### **5.1.3 Equipment**

There are various types of spreaders, spreader control units, and other equipment that can reduce the amount of deicing materials applied while improving the level of service.

#### **Sensors: Truck-Mounted or Hand-Held**

Knowing the pavement temperature is essential to making the right decision for treatment options. Most weather stations measure conditions thirty feet in the air and can differ significantly from the surface of the roadway. The two most common types of sensors are Mobile Freeze Point/Salinity Sensors and Mobile Pavement Temperature Sensors.

Hand-held infrared temperature sensors can only be used when the vehicle is stopped or moving slowly, while the truck-mounted temperature sensors take measurements while the truck is moving. A hand held temperature sensor can be purchased for as little as \$100 from an auto parts store and is an inexpensive addition to the decision making tool box. Salometers are used to determine the percent salinity of brine mixtures



**Figure 5: Hand-Held Pavement Sensor**



and are critical to have while operating a pre-wetting/anti-icing program.

#### Automated Vehicle Location (AVL)

AVL collects real time data and equipment location through GPS receivers, transmitters and software. Data is used to track salt use, rationalize the number of trucks being used and demonstrate prudent usage.

#### Plowing Capabilities

Proper plowing of the road is essential to controlling the road conditions. Snow plowing with the proper blade needs to remove as much snow as possible prior to the application of additional chemicals. Snow and ice that is left on the pavement will only work to dilute the chemical that has been applied and decrease the effectiveness. Additional applied chemical will have little benefit if the snow is not adhering to the pavement surface, when plowing is the appropriate operation.

There are many different plow types, including one-way front plows, reversible plows, deformable moldboard plows, underbody plows, side wings, expandable plows, and plows specifically designed for slush removal. Plows are hydraulically controlled and can have quick-change buffer systems allowing for a fairly short time to mount or dismount. Manufacturers have also developed plows that are hydraulically extendible. These extendable plows allow for width adjustment from 9-12 feet depending on lane width. Underbody plows are highly recommended since they can be used in conjunction with one-way front plows, side wing plows, and rear wing plows. They provide downward pressure and can scrape the roadway clean for the best snow removal results.

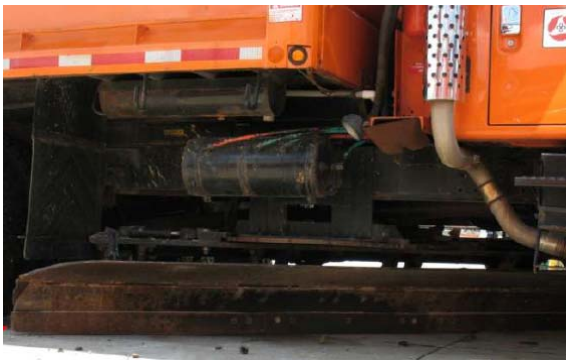
**Figure 6. Down-Pressure Plow**



**Figure 7. Moldboard Plow Designs**



**Figure 8. Underbody Plow**



**Figure 9. Underbody Plow Mid Mount Wing Single-Axle**



**Figure 10. Underbody Plow with Mid Mount Wing Tandem-Axle**



**Figure 11. Dual Mid-mount wings mount wings single axle**



### Cutting Edges

Plow cutting edges have had significant improvements in recent years. They can be made out of steel, rubber, ceramic, carbide, and synthetic polymers and can be use singly or in combination. The performance of any cutting edge is dependant on the road, the weather conditions, and the operator's knowledge. For the most efficient operations, operators should keep cutting edges as close to the pavement as possible to remove snow and slush. The use of casters or shoes on the plow is not recommended unless the road is an uneven surface. If casters are needed the downward pressure should not be on the shoe but on the cutting edge. Manufacturers have developed slush plows that use several blades in tandem. The cutting edge blade is made of steel while the trailing blade is made of rubber, which is better for removing slush. The design is used to cover a larger range of road conditions and is more effective than either blade used on its own. The use of segmented blades, which allow for closer plowing of uneven road surfaces, has also become increasingly popular.

**Figure 12. Flexible Edge / Segmented Blade**



**Figure 13. Razor Blade Cutting Edge Set-Up**



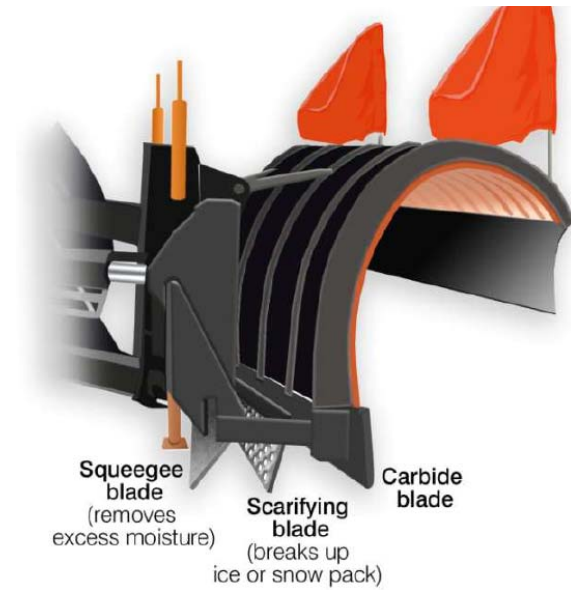
**Figure 14. Slush Blades:**



**Figure 15. Slush Blade Engaged versus Cutting Edge Engaged**



**Figure 16.  
Multiple Blade Design**



### Ground Speed Orientation

There are three factors in determining a truck's salt application rate: gate opening, speed of the spreader belt, and the traveling speed.



Ground speed oriented spreaders keep application rates constant because the belt speed in the spreader corresponds to truck speed.

Incorporating ground speed controls is one of the most critical changes that can be made to achieve salt reduction.

### **Figure 17. Operator Controls**

monitoring of the spreader control is important for the accuracy of your application rates.

Calibration and

### Spreaders

The total amount of deicing chemical used for winter maintenance is a significant influence on the type of spreader equipment needed.

Accurate spreader controls are needed to account for the amount of material being applied and should be consistent based on a full or near empty load. The spreader needs to be able to operate in a variety of conditions including very low temperatures, high moisture, and be resistant to corrosion.



**Figure 18. Slide-In Spreader**

Hoppers should be constructed so that excess salt can be removed from the spreader and so that they can be removed during the off season so the vehicle can be used for other purposes. Spreaders designed with discharge at the rear can allow for a slide-in capability that can be mounted and dismounted. Various types of spreaders include: hopper spreaders, tailgate spreaders, reverse dumping spreaders, and spreaders that are variations of these. Slide-in spreaders tend to be the most cost effective with a longer use life and are easy to maintain and clean away salt residue. They use a conveyor chain and chute system for material applications either with a spinner or direct drop to the road surface. Slide-in spreaders also have the ability to handle a pre-wetting system.

Zero Velocity Spreaders (ZVS) can optimize the use of deicing material by controlled distribution. Material is dispensed at the same



velocity as the forward motion of the truck; the two velocity components essentially cancel each other out causing the salt to drop on the road as if the vehicle was standing still. This helps reduce bounce and scatter, and reduces the required volume of deicing material. ZVS also have the capability to pre-wet.

**Figure 19. Zero Velocity Spreader** There have been some mechanical complications while pre-wetting under certain conditions. The most common issues associated with the zero-velocity spreaders can be material caking and uneven discharge. Modifications are being developed by the manufactures to refine and improve the technology of these spreaders. (O’Keefe and Shi, 2005)

#### Pre-Wetting Spreaders

Pre-wetting is typically done by adapting spreader trucks with saddle tanks and spray nozzles which apply approximately 8-10 gallons/ton of a liquid to solid deicer. It is most common for salt brine at 23% concentration to be sprayed onto solid salt as it passes through the spreader chute. Plow and spreader trucks looking to add pre-wet capabilities require investment to purchase the saddle tanks, pumps and nozzles that are capable of applying a liquid at the spreader’s spinner. As with any chemical application calibration is critical to controlling the amount applied to the roadway.

**Figure 20. Tailgate Mounted**



**Figure 21. Integrated tailgate  
225gal. capacity**



Some of the most common types of liquid spreaders are spinner type, distributor bar with nozzles, chassis-mounted, slip-in, and tow-behind. During initial start up programs, modification of existing equipment may be the most economical. Some highway agencies have been successful in modifying asphalt distributor trucks, liquid fertilizer spreaders and spreaders used for weed control. Brine has been made available for this purpose and can be purchased by municipalities from NHDOT.



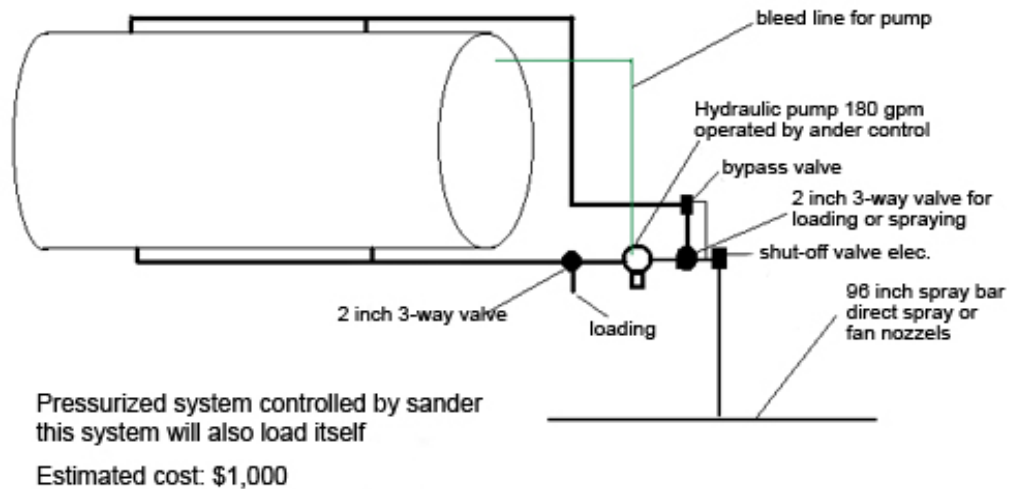
**Figure 22. Liquid Anti-icing truck with spray bar**

**Figure 23: Tow Behind Liquid Anti-Icing**



**Figure 24: Slip-In Anti-Icing Brine Unit (250 gallon capacity)**

**Figure 25: Graphic of Home-Made Brine Unit**



[http://www.iowadot.gov/maintenance/images/equipment/truck\\_back.jpg](http://www.iowadot.gov/maintenance/images/equipment/truck_back.jpg)

#### **5.1.4 Calibration**

During winter operations, changes may occur in mechanical linkages, hydraulic systems and other components. Yearly calibration of equipment allows for better control of application rates for various gate height/openings. Gate height or gate openings should be adjusted to spread the desired chemical application rate for each set of unique conditions. Re-calibration should be done if any changes are made to the equipment or if a different deicing material is used. In addition to manufacturer specifications, see Appendix B for Hydraulic-Run Spreader Calibration and Appendix C for Pony Motor-Run Spreader Calibration. Keep a record of the calibration results with the vehicle and refer to it for the application settings recommended for the various weather conditions.

#### **5.1.5 Storage and Site Management**

In addition to managing how salt is applied to parking lots and roadways, it is also important to manage how dry salt, pre-wet salt, salt brine, salt/sand mixtures, and snow piles are stored and handled. This section was adapted from [DES Fact Sheet WD-DWGB-22-30](#).

Chloride storage facilities can contribute to both surface and ground water contamination. The location of a storage facility should not be in an area that is environmentally sensitive. Avoid areas where there are wells, reservoirs, or within the footprint of stratified drift aquifers.

Ideally deicing material storage facilities should be completely enclosed, with storage and working areas on impervious surfaces such as asphalt or



coated concrete. Buildings should have concrete foundations and can be designed using dome, barn, or fabric style structures.

**Figure 26. Improper Site Management**



There should be storm water drainage controls to prevent runoff water and snow melt from contacting or running through loading and material storage areas. Overhead cover to protect material from exposure to snow and rain should be installed to minimize runoff and inventory loss. A fixed roof is preferred over a tarp,

because it is difficult to keep storage piles completely covered with tarps during winter months and storm events.

As a general practice, site drainage should direct clean storm water away from the operations and storage areas in order to keep the stockpiles as dry as possible. In new facilities or facilities that are being retrofitted drainage that is contaminated with salt should be directed to a sewage treatment plant (subject to municipal approval), collected for use in pre-wetting activities or sent for proper disposal.

#### Salt Storage Structures

- All salt and sand/salt mixtures should be stored on pads of impermeable asphalt or concrete. Storage and loading areas should have an impermeable floor constructed of asphalt, concrete or other suitable material that extends around the buildings and work area exterior. The area should be sloped away from the structure to prevent storm water from entering the loading areas or structure.
- Concrete pads and walls should be treated to prevent concrete deterioration.
- Structure hardware should be galvanized and concrete block buildings should be waterproofed inside.
- If using a three sided building, the exposed salt at the open end should be covered.
- Storm water and snowmelt runoff should be properly controlled. Building floors and storage pads should be sloped to prevent ponding and allow any water to drain away from the storage piles.



**Figure 27.  
Town of Derry NH  
Salt Storage**

### Brine Storage and Management

In recent years brine has been used on roads prior to storms as an effective ice preventative, reducing the amount of deicing materials needed during a storm event. The water that runs off storage and loading areas can be collected into watertight tanks or lined basin(s) and reused. Any brine storage should be designed with inert materials that are compatible with salt.

Brine stored in holding tanks must be managed so that there are no releases to drains, groundwater or surface waters. If there is a floor drain in a building where brine is stored, it must be connected to a municipal sewer, routed to a registered holding tank or permanently sealed. For the NHDES fact sheet on floor drains refer to Appendix D.

Storage ponds or collection basins used for brine storage must be lined and must not receive runoff from areas other than the storage and operations areas. The basin itself must be impermeable to prevent infiltration of the collected water into the ground. The basin may need a roof or cover to reduce the accumulation of snow and rain water. The collection of this runoff water would only be necessary during the winter maintenance months (November through March). During the remaining seven months of the year, the non-brine stormwater can be redirected from the brine storage to a natural discharge point.

The preferred management option for any brine collected is for use as a pre-wetting agent for roads prior to winter storms. The release of this collected water to the ground, groundwater, or a stormwater system during operation or at season's end is not permissible and as a consequence, this type of runoff management may require disposal of the brine by one of the following methods:

- 1) Discharge directly to a publicly owned treatment works (POTW) with local approval;

- 2) Pumping and transporting the salt water to a POTW system by tank truck;
- 3) Evaporation; or
- 4) Treatment to remove salt and onsite discharge under a Nondomestic Wastewater Registration.

All liquid storage tanks should be protected from impact by vehicles moving about the yard and be located such that spilled material can be contained and retrieved in the event of a tank or piping failure. Secondary containment should be provided around large liquid storage tanks.



**Figure 28. Proper Brine Storage**

#### Snow Storage and Disposal

The environmental effects of disposed snow result from high levels of sodium chloride, sand, debris and contaminants from automobile exhaust. It is the debris contained in plowed snow that makes it illegal to dump snow directly in water bodies. RSA 485-A:13,I(a) prohibits discharging wastes to surface waters without a permit. Groundwater is sensitive to snow dumping due to the high levels of sodium chloride in plowed snow. RSA 485-C:12 prohibits the sitting or operation of snow dumps within classified wellhead protection areas.

**Figure 29. Snow Storage and Disposal**

The following guidelines are designed to select safe places to dump plowed snow. Snow dumps are kept out of water bodies due to the litter and debris content. Litter and debris do not belong on the land surface either; after the snow melts, all litter and debris must be collected and disposed of properly.



- Disposed snow should be stored near flowing surface waters, but at least 25 feet from the high water mark of the surface water.

- A silt fence or equivalent barrier should be securely placed between the snow storage area and the high water mark.
- The snow storage area should be at least 75 feet from any private water supply wells, at least 200 feet from any community water supply wells, and at least 400 feet from any municipal wells. (Note: Snow storage areas are prohibited in wellhead protection areas [class GAA groundwater].)
- All debris in the snow storage area should be cleared from the site prior to snow storage.
- All debris in the snow storage area should be cleared from the site and properly disposed of no later than May 15 of each year the area is used for snow storage.

Onsite Management: Delivery/Handling/Loading

- All sand and sand/salt mixtures temporarily out in the open should be covered to prevent salt from being washed or blown from the pile.
- If a permanent covered work area is not possible, then storage and handling activities should be conducted on impermeable (bituminous) pads. Any deicing materials left outdoors should be completely covered with waterproof tarpaulins.
- All surplus materials must be removed from the site when winter activity is finished.
- Working areas should be bermed and sloped to allow snow melt and stormwater to drain away from the area. In some cases, it may be necessary to channel water to a collection point, such as a sump, holding tank, or lined basin for collection.
- Storage and distribution should only be conducted during the fall/winter season.
- Spreaders should not be overloaded such that material spills off the vehicle. A plan for loading operations to prevent overfilling vehicles and eliminating material spillage during transportation should be developed and implemented.
- Salt spilled at the storage yard and loading areas should be collected and returned to the storage pile.
- Annual inspection and repairs should be carried out prior to the start of each season.
- Ongoing inspection of storage structures, work areas, and deicing liquid storage tanks should be carried out during the season.
- Solid bagged materials should be stored securely, indoors if possible.
- Spreaders should only be washed at a location where the wash water is properly managed. Please refer to Appendix L for The DES fact sheet on the Management of Vehicle Wash Water.

- Liquid storage tanks should be designed such that a plumbing failure will not result in release of the contents. Backflow prevention may be necessary on some plumbing applications.

## **5.2 Information: Evaluate and Monitor Conditions**

Knowing current and expected conditions is essential for planning snow and ice control operations. Weather and road conditions change constantly and must be monitored. The decision to initiate treatment can only be made if accurate information is available. Treatment options chosen should be modified as necessary to address road conditions as they develop.

**Monitor and evaluate the following information to assist in making the right treatment decision:**

- Start and end times of precipitation
- Type of storm, precipitation type and amount expected, wind, intensity
- Pavement, ambient and dew point temperatures and trends
- Road conditions and surfaces
- Post-storm forecast
- Traffic and accident information

Information can be obtained from local, state, and national weather and road services. Access to information can be obtained by phone, radio, internet radar forecasting services, RWIS data, and by truck mounted or hand-held pavement temperature sensors. Private weather and road condition forecasting services are also available by contract at a cost to the subscriber.

Truck mounted and hand-held infrared pavement temperature sensors are critical tools for operators because they provide real-time data and allow for application rate adjustments to be made accordingly.

Communication among operators and law enforcement officials can assist in making snow and ice management decisions.

### 5.2.1 Weather Information Resources:

- Intellicast is an internet weather resource that provides detailed information regarding storms, temperatures, and forecasts by radar and satellite maps.
- There is also a wxMap function that is interactive by the user. Additional information can be obtained at: [www.intellicast.com](http://www.intellicast.com)
- Accuweather is an internet web site resource that provides weather information by location, providing forecasts, radar and maps, and severe weather alerts. Additional information can be obtained at: [www.accuweather.com](http://www.accuweather.com)
- WMUR Storm Watch 9 internet web site provides local New Hampshire weather with live doppler radar, maps, video casts, alerts, temperature outlooks. Web site information can be obtained at [www.wmur.com/weather/grid.html](http://www.wmur.com/weather/grid.html)
- The National Weather Service website at: [www.noaa.gov](http://www.noaa.gov)
- NOAA Weather Radio-(NWR) a service of the National Oceanic and Atmospheric Administration of the U.S. Department of Commerce provides continuous broadcasting of up to date weather conditions from the National Weather Service office. Broadcast information can be obtained on the VHF public service band at the following frequencies: 162.400 / 162.425 / 162.450 / 162.475 / 162.500 / 162.525 / 162.550

Or online at:

[www.nws.noaa.gov/forecasts/graphical/sectors/newhampshire.php](http://www.nws.noaa.gov/forecasts/graphical/sectors/newhampshire.php)

- RWIS (Road Weather Information System) – RWIS units contain Environmental Sensing Systems (ESS) that measure variabilities in ambient air temperature, relative humidity, visibility, precipitation, sub surface temperatures, and sometimes traffic patterns. Data is then collected by the Remote Processing Unit (RPU) which is used to assist in winter maintenance decisions. RWIS can help minimize chemical applications and optimize operator resources as well as to assist in weather events and advisories. The



**Fig. 30 RWIS Station**

Department of Transportation currently operates RWIS towers near the Salem rest area off I93 exit 1, in Derry, at the junction of I93 and 101 in Manchester, and several other locations around the state . It is recommended that the municipalities consider coordinating with DOT to use the weather and pavement condition data provided by RWIS to effectively respond to

upcoming weather conditions and storms. For additional information regarding station locations within New Hampshire please visit the DOT informational poster on RWIS at: [http://www.nh.gov/dot/org/projectdevelopment/materials/research/projects/documents/12323i\\_poster.pdf](http://www.nh.gov/dot/org/projectdevelopment/materials/research/projects/documents/12323i_poster.pdf)

### **5.2.2 Pavement Temperature**

The two most critical factors that can produce a winter road hazards are pavement temperature and the dew point/precipitation rate. Pavement temperature, not air temperature, is the deciding factor for treatment type and duration. The pavement temperature directly effects the formation, development, and breaking of a bond between fallen or compacted precipitation and the road surface. The pavement temperature also determines the effectiveness of any applied chemicals. Pavement temperatures can be significantly affected by the following:

- Air temperature trends - may indicate what the pavement temperatures are likely to do.
- Subsurface temperatures - warm subsurface temperatures (typically in the fall) will help pavement hold heat and keep the pavement temperature from dropping. During the winter and spring, pavement temperatures will drop quickly because the ground is still cold. Pavement temperatures can be considerably colder than the air temperature in the spring, creating frost and ice conditions.
- Time of day - The amount of sunlight and the angle at which the sunlight hits the road will influence the pavement temperature and the melting effectiveness of any chemical that has been applied.
- Cloud cover - Daytime cloud cover can cause pavement temperatures to cool. During the night, lack of cloud cover causes heat to escape and cooling to occur.
- Wind speed and direction - can have either a warming or cooling effect.
- Precipitation rate - the amount of precipitation; whether it is snow, freezing rain, or sleet that falls within a given time will affect the temperature of the pavement.

Black ice or frost will form on a very cold pavement surface when air has cooled to its dew point. The dew point is the saturation temperature of the air. The higher the dew point, the greater the moisture in the air. The lower the dew point, the drier the air. When the air temperature is cooled to the dew point, water vapor in the air will condense into either a liquid or a solid.

**It is essential to know the current pavement temperature, dew point, and weather forecast to accurately treat snow and ice problems.**

### **5.2.3 Traffic, Road Surface, Beat**

Vehicles can affect the pavement surface in many ways. Vehicles can compact the snow, abrade it, displace it or disperse. Heat from tire friction, engines, and exhaust can add measurable heat to the pavement surface. Vehicle action and road surface can influence, both positively and negatively, the effectiveness of snow and ice control. The volume of vehicle traffic should be considered when establishing levels of response.

Road surfaces such as asphalt, porous pavement, or gravel and locations such as intersections, bridges, shaded areas, steep grades, sharp curves, on/off ramps, and areas near high traffic facilities should be given special consideration along with areas prone to snow drifting or that experience sudden icing.

Have efficient and effective beats planned for your staff and prepare procedures for call outs and call backs. Have a description of beat length, the average time to run the beat along with the amount of chemical needed to complete it.

Road variables to take into consideration include:

- Geometrics – bridge decks, steep grades or sharp curves will influence the application rate required.
- Cold Spots – Cold spots at higher elevations or in shaded areas may require application and treatment techniques that are different from the rest of the route.
- Pavement Surface – surface consistency and variation will affect the types of equipment and techniques used.
- Lanes – the number of lanes being treated will effect the cycle time of the beat.
- Speed – truck speed will vary considerably due to traffic, buildings, pedestrians, and road type.
- Time of day – The amount of sunlight and the angle at which the sunlight hits the road.



### **5.3 Decision: Treatment Technique and Selection of Material**

Winter maintenance practices can use reactive approaches, proactive approaches or a combination of the two.

A reactive approach (de-icing) is choosing to apply road salt (or other deicing chemical) after the onset of a storm to break down the bond which has already formed between frozen pavement and the pavement surface. This approach is seen as the traditional method of snow and ice removal and is not as effective in preventing hazardous road conditions as using a proactive approach. Reactive approaches use more deicing materials in order to remove accumulated materials, take longer to reestablish and/or maintain the level of service to roadways and parking lots and have higher environmental and infrastructure impacts.

Selecting a proactive approach (anti-icing) prevents the formation of a strong bond between frozen precipitation and the pavement surface so that precipitation can be easily removed mechanically. Using proactive approaches have the least amount of environmental and infrastructure impacts, allow a better level of service to the roadways to be maintained, and decrease the amount of callbacks.

In the next section, salt reduction best management practices are recommended for all sectors. Practices recommended will not decrease the level of service to roadways and/or parking lots, and as long as they are completed properly, may increase the level of service while reducing the level of chlorides being applied.

#### **5.3.1 Treatment Techniques: Plow, Anti-Ice, De-ice**

##### Mechanical Removal

Increasing mechanical removal is one of the best ways to limit salt use. Mechanical removal should begin with onset of the storm and continue throughout the storm. If de-icing chemicals are to be used, the primary goal is to remove as much snow or loose ice before applying chemicals. This maintains the chemical's effectiveness without concern for excessive dilution. Most snow removal policies in New Hampshire call for plowing to begin if there has been at least a 4-inch accumulation of snow on the road surface. Revisions should be made to incorporate more aggressive mechanical removal so accumulation on roads and parking lots does not occur. Anti-icing prior to the storm event should also be combined with mechanical removal to be most effective.

### Anti-icing

Anti-icing is a preventative or proactive strategy to winter maintenance and is often the first action taken. Anti-icing is a technique where a snow and ice control chemical is placed on the roadway well in advance of a snow, ice or frost event. Application of an anti-icing material is designed to prevent and/or weaken the precipitation's bond to the pavement, making removal of snow or ice easier than with traditional deicing methods, and buys critical response time. The applied chemical remains on the pavement surface and activates with moisture when precipitation begins. Heavy traffic volume, the amount and type of precipitation, pavement temperature, and mechanical removal of snow will influence the rate of dilution of the anti-icing chemical.

Anti-icing on roadways is most commonly done with liquid applications, however anti-icing is not limited to using liquids. Using solid pre-wetted materials for anti-icing can be effective in areas where the materials are not quickly removed from the surface by traffic, such as sidewalks and parking lots. The application timing is essential with any anti-icing program. It is recommended that accurate weather forecasts, including storm length, precipitation type and temperatures, be incorporated into the decision when applying anti-icing materials.

Liquid brine is directly applied to the pavement surface in anticipation of an upcoming weather event. Brine can be applied 12-18 hours before the event and should be conducted during times of low traffic and pedestrian travel. The brine is applied with a liquid application in streams, in controlled amounts. Brine streams should be placed 8"-12" apart to dry on the pavement surface. By applying in rows with bare pavement in between it will reduce the potential for slippery conditions to occur depending on the chemicals used. Once frost or snow begins to fall, the moisture will reactivate the dried strips into brine that help prevent binding of snow/ice.

Anti-icers will work until the eutectic temperature of the solution meets the pavement surface temperature. Refreezing will occur when an ice control chemical dilutes and melting stops at a given surface temperature. Salt brine should not be applied if the temperature is expected to drop below 20° F to prevent. Calcium chloride (CaCl) or magnesium chloride (MgCl) brine is not recommended if pavement temperatures are expected to exceed 28°F, which may create slippery conditions. For proprietary brine blends please refer to the manufacturers recommendations for application timing and appropriate temperature ranges. The

following table provides data on the lowest practical melting temperature for several different anti-icing brines.

**Table 7. Lowest Practical Melting Temperatures**

	Sodium Chloride (NaCl)	Calcium Chloride (CaCl <sub>2</sub> )	Magnesium Chloride (MgCl <sub>2</sub> )	Calcium Magnesium Acetate (CMA)	Potassium Acetate (KAc)
Concentration %	23	30	27-30	32	50
°F	15	-20	-10	20	-15

Over application of brine at any temperature has the ability to produce slippery road conditions; always follow application guidelines. Reapplication of brine is not always necessary if residual remains; it can still be active even days later. For the UNH T2 Best Management Practices fact sheet on Anti-icing please refer to Appendix E.

Benefits from anti-icing are:

- provides a higher level of service throughout a storm
- keeps snow in a plowable condition
- requires less chemical (e.g., salt, etc.)
- improves roadway friction and lowers accident rates
- decreases maintenance and clean up costs
- road conditions can return to bare pavement faster than with deicing
- reduction or elimination of abrasives
- provides bare pavement for some events
- leads to faster cleanup after the storm has ended
- reduces environmental impacts
- reduces plowing time and overtime usage as well as operator fatigue
- reduces traffic delays and leads to fewer accidents
- provides significant cost savings over time
- can be applied during non-rush-hour traffic or while businesses are closed.

Deicing

Deicing is the winter road maintenance practice of applying solid deicer to the top of a layer of snow, ice or frost that is already bonded to the pavement. Deicing is the most common practice used currently in the state of New Hampshire. Deicing is a reactive

approach that weakens the freeze bond to the pavement so that the frozen precipitation can be removed mechanically. Using solid deicers can result in up to an 80% loss of material to the roadside due to bounce and scatter. A Montana study (Williams, 2001) found that deicing typically requires 5 times the amount of chemical product that anti-icing requires.



**Figure 31. Road Conditions Anti-Icing vs. De-Icing**

**5.3.2 Selection and Use of Materials**

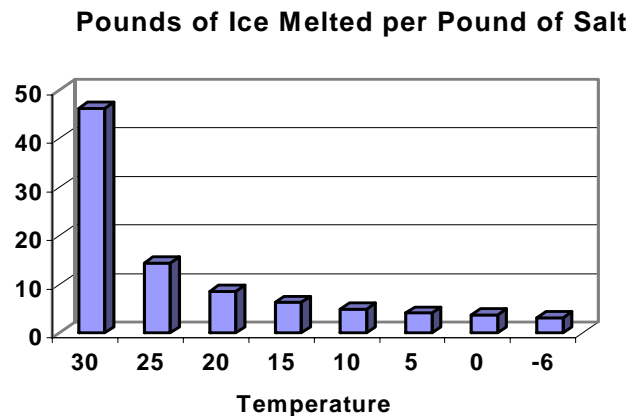
Material selection is dependent on many factors, including: environmental impact, product availability, practical melting temperature, application rates, equipment capacity, roadway systems, weather conditions, safety and liability, and associated costs.

It is also important to note that winter road maintenance technologies are rapidly changing due to industry and environmental needs. It is essential to keep informed of new practices, technologies, and products that can contribute to the safety of the environment and the public. All stakeholders should consider an annual review and implementation of the most appropriate current technologies.

**Salt (Sodium Chloride/ NaCl)**

Salt is the most widely used snow and ice control product. When salt is applied in solid form it first has to dissolve into a brine before it can melt or prevent ice from bonding to the pavement. It is a freeze point depressant which

**Figure 32.  
Melt vs. Temperature**



means that when mixed with water, depending on the concentration, it will lower the temperature at which the solution freezes. Solid sodium chloride loses its effectiveness (has difficulty going into solution) when temperatures fall below 15° F. Applications of dry salt below this temperature, even at high rates, will not result in snow or ice melting; therefore, it is critical that salt is applied at the appropriate pavement temperature. The average cost of NaCl is \$58/ton or about \$0.07 a gallon for 23.3 percent brine solution.

Dry salt that is applied directly to roads does not all remain in the targeted application area. The salt grains bounce and scatter after being applied and are blown off the pavement surface. With less salt retained on the road additional treatments or higher than needed application rates are required. For best effect with the least environmental impact salt should be pre-wetted with brine rather than applied in dry form. Refer to Appendix F for additional information regarding how salt works and Appendix H on pre-wetting salt.

#### Other Chlorides

Calcium(CaCl) and magnesium chloride(MgCl) are often used as salt alternatives; however, they have the same impact on water quality since they both contain chlorides. These chemicals work differently than salt in that they do not require heat energy to go into a solution; instead they give off heat when they go from a solid into a solution. Their main benefit is having lower eutectic temperatures, providing more melting power at lower temperatures. They are more effective in dry, cold conditions as compared with salt. It is not recommended that they be applied at high application rates or when pavement temperatures are above 28 degrees Fahrenheit due to an increase in slippery road conditions. They are both corrosive and may contain corrosive inhibitors. The cost associated with making brine using Mg chloride averages between \$0.45-\$0.75/gal and for Ca chloride the cost of brine is around \$0.82/gal and \$250/ton for flake.

#### Alternative De-Icers

Environmental impacts associated with the selection of alternative deicers should be considered. Road salt alternatives are primarily proprietary and are not well documented in scientific literature. Available data is limited, particularly regarding long-term environmental impacts.

Most agricultural by-products are not as good at melting ice; however, they do slow the formation of ice crystals, making them good for anti-icing and pre-treating. Some agricultural byproducts

have freezing points near -30° F. They are less corrosive than many conventional materials. Most products are derived from the processing of grains or other agricultural products. They have a higher cost associated with them and most often are mixed with products such as magnesium chloride.

**Table 7. Generalized Environmental Concerns for Chloride Alternatives**

Product	Chemical Formula	General Information	Environmental Concern
Calcium Magnesium Acetate (CMA)	CaMgAc	powder, crystal, pellet or liquid, non-corrosive, cost around \$1,000/ton or \$1.30/gal	Organic content leading to BOD
Potassium Acetate (KA)	KAc	liquid, non-corrosive, 50% concentration cost around \$3.00/gal	Organic content leading to BOD
Agricultural By-Products	N/A	mostly proprietary, can be derived from corn, beet, alfalfa, alcohol, grains, or molasses. Less corrosive, lowers freeze point, generally not good at melting alone. Avg cost \$1.00/gal	Organic content leading to BOD, Heavy Metals, nutrient enrichment by phosphorus, nitrogen
Urea (Urea, Ammonia)	Urea, Ammonia	fertilizer with high nitrogen content, corrosive, cost around \$350.00/ton	Rapid break down and release of Ammonia, Fertilizer leading to nutrient enrichment, algae blooms and BOD

Since Dinsmore Brook flows into Cobbetts Pond and Cobbetts Pond is impaired for dissolved oxygen saturation and total phosphorus, agricultural by-products are not recommended, except in small quantities to pre-wet salt.

Addition of organic compounds (e.g., acetate or mixed organic matter from biomass) may cause deoxygenation in the water, which in turn could cause the release of potentially harmful substances such as heavy metals into the groundwater and could be a cause of taste and odor problems (NCHRP, 2004).

Brine

Using brine is the most cost effective way to anti-ice or pre-wet. Brine is widely used in other states because it is easy to produce, economical and effective for events occurring at moderate or subfreezing temperatures. There are many types of products that are used to make brine such as sodium chloride (NaCl), magnesium chloride (MgCl), potassium acetate(KA), calcium magnesium acetate(CMA) as well as proprietary blends. Each product has its

advantages and disadvantages. For example calcium and magnesium chloride brines are effective at lower temperatures than sodium chloride, but they are more expensive (45-80 cents/gallon for 28% solution) and can be difficult to handle. Also, calcium and magnesium chloride residue on road surfaces can attract moisture at lower relative humidity, unlike sodium chloride brine, that may result in dangerous, slippery road conditions.



**Figure 33. Brine Making Facility**

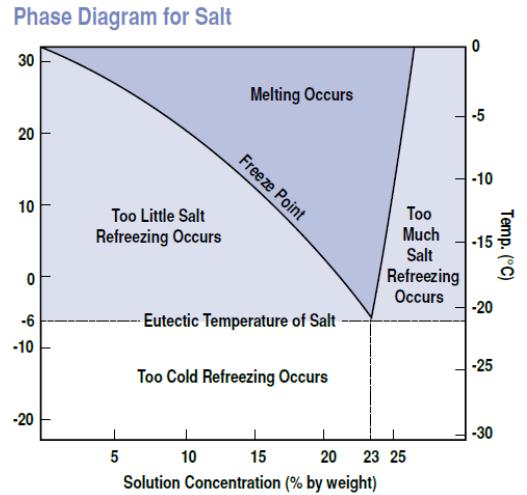
Chloride alternatives such as potassium acetate, used predominately at airports due to its reduced corrosion effects, cost about \$7 per gallon. Agricultural by-products cost about \$1-\$2 per gallon in comparison to the cost of sodium chloride at about \$0.07/gallon (assuming rock salt is \$58/ton). The New Hampshire Department of Transportation is currently offering to sell brine and brine blended with Ice Begone to the municipality from the Derry Interstate shed #528 with associated costs of \$0.15/gal. and \$0.45/gal. respectively.

The most commonly used brine is made using sodium chloride (rock salt) and water. Sodium chloride brine solution needs to be 23.3 percent salt to work effectively. When a chemical is mixed with water, or goes into solution it will change the freezing point of the water, which is called the eutectic temperature. As the concentration of the mixture changes, or dilutes on the road surface, the melting temperature also changes. Solubility of various chemicals also varies with temperature, with lower solubility at lower temperatures. Salt brine produced at 23.3 percent has a lowest practical melt temperature at around 15° F; application on roads with pavement temperatures below this are not recommended as the salt brine can refreeze causing slippery road conditions. The following graph obtained from the salt institute shows the effects of salt brine and freezing at various temperatures.

chloride, but they are more expensive (45-80 cents/gallon for 28% solution) and can be difficult to handle. Also, calcium and magnesium chloride residue on road surfaces can attract moisture at lower relative humidity, unlike sodium chloride brine, that may result in dangerous, slippery road conditions.

Chloride alternatives such as potassium acetate, used predominately at airports due to its reduced corrosion effects, cost about \$7 per gallon. Agricultural by-products cost about \$1-\$2 per gallon in comparison to the cost of sodium chloride at about \$0.07/gallon (assuming rock salt is \$58/ton). The New Hampshire Department of Transportation is currently offering to sell brine and brine blended with Ice Begone to the municipality from the Derry Interstate shed #528 with associated costs of \$0.15/gal. and \$0.45/gal. respectively.

**Figure 34. Phase Diagram**



The basic equipment used in brine making is a mixing tank, a holding tank, a pump, and a salometer. It is recommended that brine mixing and storage be indoors to reduce the risk of freezing when temperatures are below 0° F; a circulatory pump may be used to reduce this risk if outdoor storage is the only option. If a mixing facility is not available or desired brine may be purchased from an independent vendor. DOT is currently willing to sell brine to the town of Windham for a pre-wetting trial period.



**Figure 35. Salometer**

Use the following guidelines for working with brine:

- Salometer reading should be 88.3 for 23% solution
- Specific gravity of 1.179 at 60° F
- Freeze point of -5.8° F for 23% solution
- One gallon of saturated brine contains 2.647 pounds of salt and weighs 10.027 pounds.
- One gallon of water dissolves 2.991 pounds of salt to produce 1.13 gallons of saturated brine.
- One ton of salt will produce 755.5 gallons of saturated brine.
- Chemical additives can be mixed with brine to further lower the freeze point.

For information about the proper storage of brine, see the Brine Storage and Management section. Refer to Appendix G for the New Hampshire Best Management Practices fact sheet on making brine.

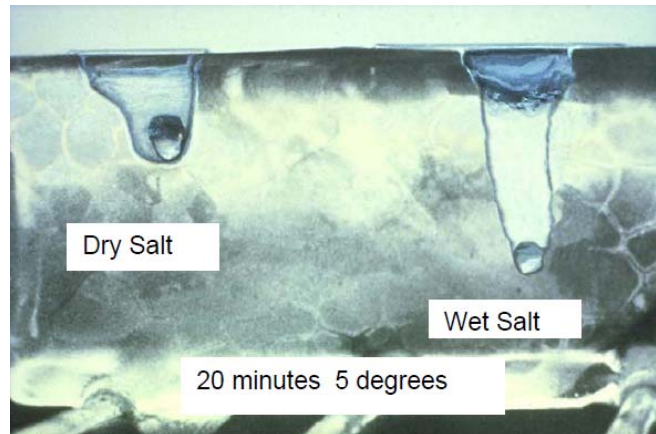
#### Pre-Wetting

Pre-wetting is a term referred to a liquid deicer that is applied to a solid-based deicer in order to create a quicker reaction time for the solid deicer to begin melting snow and ice. Salt doesn't work until it is in solution, so it is recommended that all dry salt be pre-wetted regardless of the temperature. By introducing moisture into salt prior to application, the results are a quicker melting action, reduced bounce and scatter of material, and a reduced application rate.

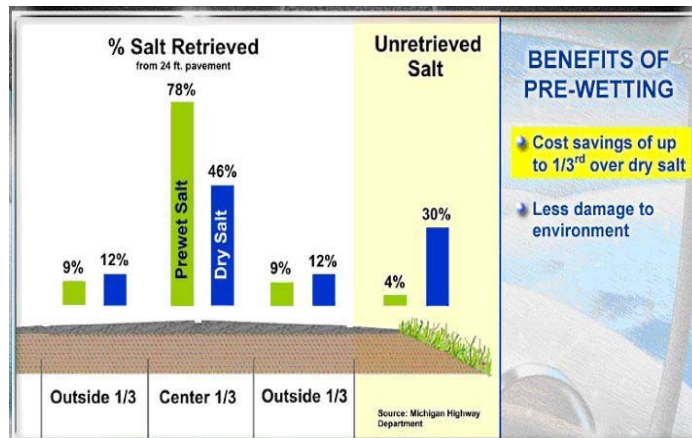


**Figure 36. Ice Melting**

With a quicker melting action the application rate of pre-wet salt can be decreased by approximately 20 percent over dry salt, which saves money, increases level of service, and reduces chloride in the environment.



Pre-wetting decreases the amount of material that resides outside the target application area due to bounce and scatter. In a Michigan Highway Department study it was found that 20 percent to 30 percent of dry salt applied was immediately removed from the target



**Figure 37. Bounce and Scatter of Salt**

shown to increase the performance of solid chemicals and their longevity on the roadway surface, thereby reducing the amount of materials required. (O’Keefe and Shi, 2005)

Pre-wetting can be accomplished at the stockpile, in the body of a truck, at the spinner, and at the auger.

Wetting stockpiles can be done with a liquid injector that uses special nozzles that inject deep into the pile, but this method is not readily used due to the level of management required. The degree of coating on dry salt is highly dependant on the skill of the operator

and frequent reworking of the pile is needed. Because of leaching risks, all stockpiles should be covered and on an impervious pad.

Another method of pre-wetting at the pile is to move the needed amount of dry salt into an area for mixing. Spray liquid deicer onto the smaller pile at the desired rate, mix, and then load into the truck.

**Figure 38. Overhead Pre-Wet Spray System**

Spraying truckloads is accomplished by spraying liquid chemical onto a loaded truck, or while material is being loaded to the truck with an overhead spray-bar system. Spraying stockpiles and truck loads is not as practical since granules are not



uniformly coated and liquid may drain out of the solid material. Performance on the road may not be consistent throughout the route.

The most efficient method is to pre-wet while salt is being discharged from the chute or at the spinner.

Solutions for pre-wetting can include sodium chloride brine, calcium chloride, magnesium chloride, potassium acetate, calcium magnesium acetate and various agricultural products.

For the UNH T2 best management practices fact sheet on Pre-wetting please refer to Appendix H.

**If pre-wetting salt is not an option then pretreated salt may be available for purchase from your local supplier. It is important that the pre-wetted salt be stored in a covered area or within a building to reduce leachate and material waste.**

#### Abrasives

Abrasives (sand and fine mineral aggregates) provide temporary traction on roads, hills, intersections or other problem areas. Abrasives do not melt ice or snow. They are generally used in very cold temperatures when other materials are not as effective. Abrasives, once applied, are quickly dispersed off the road surface by traffic, therefore they are most beneficial in very low traffic areas.

**Figure 39. Abrasives Clean Up**



Abrasives are not cost effective when considering the handling, application, clean up, and disposal of material. There is generally no advantage gained from the routine use of abrasives in a winter maintenance program since more applications of a salt/sand mix are required to achieve the same level of melting as straight salt.

Negative environmental impacts from sand use also exist. Traffic breaks down abrasives into smaller particles and contributes to air pollution. Abrasives make their way into waterways, filling in the spaces between bottom substrates and choking out aquatic habitat. Abrasives also clog ditches and storm drains, requiring extensive clean up.

Abrasives can also be contaminated by the road surface from heavy metals such as lead, zinc, iron, copper, cadmium and chromium that are released from vehicles. Street sweeping materials cannot be used as fill unless they are tested and found to be clean. If street sweeping materials are contaminated, proper disposal is required at specialized landfills.

Because abrasive applications offer the limited benefit of temporary traction on roads, it is recommended that abrasives should not be a routine operation of an anti-icing program. Sand is more beneficial for pedestrian applications, such as parking lots and sidewalks.

If sand is to be used, a common practice is to add a small amount of salt to keep it in a workable and spreadable condition. Using standard uncompacted densities for salt (2,000 lbs/yd<sup>3</sup>) and sand (2,700 lbs/yd<sup>3</sup>), the recommended ratio of salt to sand is about 0.4 percent, or 100 pounds of salt to one cubic yard of sand. In extreme cold conditions these rates may be increased if the sand pile freezes or if alternatives such as calcium chloride or other deicer with a lower freezing point can be used.

The use of “sweetened” sand/salt mixtures like 50/50 is wasteful, inefficient, and has high environmental impact.

Sand piles that have been mixed with salt or other deicing chemical to avoid salt leaching should be covered or enclosed

## **5.4 Action: Application Rates and Practices**

The goal of winter operations is to maintain the specified Level of Service while using the minimum practical amount of chemical. Spreading rates and the timing of application are decisions that need to be made based on variables in weather conditions.

Although there are no firmly set application rates due to these variables, it is feasible for guidelines to be established based on known data. With continued data collection and by performing application rate studies these recommendations can be modified based on experience.

The approach to snow and ice control should be proactive. Therefore, it is recommended that anti-icing be the preferred method of operations when conditions permit. Mechanical removal of snow with proper plow types and cutting edges should be used to ensure adequate cleaning of the roadway prior to secondary chemical application. When applying chemical it is best managed by the use of ground speed oriented spreaders.

Appendix I contains application rate guidelines established by for roads and Appendix J contains application rate guidelines established for parking lots. The recommendations are based on data issued in Appendix B of the New Hampshire DOT Salt Management Plan and are derived from recommendations set by New York State Department of Transportation (NYDOT). They are in chart form with various winter conditions, temperatures, and treatment options for dry rock salt and pre-wet rock salt.

Application rate guidelines for straight liquid salt brine (23 percent concentration of NaCl) chemical are provided in Appendix M. They are based on data issued by the City of Hamilton, New Jersey and are recommended as a starting point, to be adjusted as experience dictates. Caution should be used as over-application of salt brine may cause slippery road conditions.

The following chart is a range of application rates for a variety of treatment options. Data sources are identified next to the recommended rates. The rates should be adjusted depending on various weather conditions and temperatures. In general lower rates are used at warmer temperatures around 28° F - 32° F and higher application rates are used at temperatures below 28° F. For temperatures below 15°F liquid chemical, salt, and prewet may not be beneficial due to chemical inactivity, increased chance of rapid freeze, and application rates that would be too high to be cost effective. Verify your products effective melting temperature prior to application and as a general rule use less chemical if the temperature is rising and more chemical if the temperature is falling.

**Table 8. General Application Rates**

	Dry Salt (lb.)	Salt prewet with Brine (lb.)	23% Salt Brine NaCl (gal.)	27% Mg Chloride MgCl (gal.)	32% Ca Chloride Mg/Cl (gal.)	Potassium Acetate (Ka)	Calcium magnesium Acetate (CMA) (gal.) / (lb.)	Sand (lb.)
Roads (per/lane mile)	100-450 NYDOT	80-350 NYDOT	30-40 NYDOT	28-30 NYDOT	33-36 NYDOT	10-30 UNH T2	15-25 / 200-400 UNH T2	500-800 NH DOT
	250-300 NHDOT	80-320 MN05	40-60 NHDOT/ UNH T2	15-25 MN05	15-60 UNH T2			400-800 UNH T2
	100-400 MN05/ UNH T2	up to 250 FHWA	20-50 MN05	15-35 UNH T2	25-32 WI			
	100 WI		44 WI	26-33 WI	(89-111 dry per lb.) WI			
	up to 250 FHWA		25-80 NJ	(74-94 dry per lb.) WI				
			25 FHWA					
Parking lots (per/1000 sq.ft.)	3-14 T2	3-11 T2	0.5-0.75 T2	0.1-0.2 MN06				
	0.75-3 MN06	0.75-2.5 MN06	0.2-0.4 MN06					

NYDOT- Highway Maintenance Guidelines Snow and Ice Control 2006  
 NHDOT – Winter Maintenance Snow Removal and Ice Control Policy 2001  
 MN05- Minnesota Snow and Ice Control Field Handbook for Snowplow Operators 2005  
 MN06- Minnesota Winter Parking Lot and Sidewalk Maintenance Manual 2006  
 NJ- Hamilton, New Jersey- Implementing an Anti-Icing Policy at the Municipal Level 2007  
 T2- University of New Hampshire Technology Transfer Center, Guidelines for Parking Lots 2010  
 UNH T2 – Technology Transfer Center Salt Reduction Workshop for Supervisors 2010  
 WI- Wisconsin Transportation Bulletin, Pre-Wetting and Anti-Icing, No. 22  
 FHWA – Federal Highway Administration, Manual of Practices for an Effective Anti-Icing Program

**The most efficient and effective tool for reducing chloride levels without decreasing the level of service is selecting the appropriate time and method of snow and ice removal for each storm.**

### **5.4.1 Sidewalk Treatment**

Sidewalks are often the most over-salted areas in winter maintenance, due to the perceived need for “precautionary” measures or to “burn-off” snow. Having salt and sand on indoor entryways and on floors can lead to slippery conditions inside buildings. To reduce the amount of deicer that is carried into a building, focus should be on aggressive mechanical



**Figure 40. Sidewalk Spreader**

removal of snow and proper application rates. When applying the deicing chemical disperse material using a drop spreader and install shields to



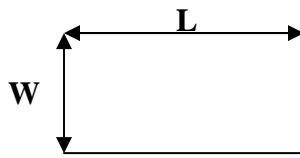
restrict the spread pattern on rotary spreaders. This will keep the deicer in the area it is need while protecting nearby vegetation. Equipment calibration will assist in proper application rates for the area being treated. These steps will produce safer walking surfaces both on the sidewalk and in the building, providing a safer environment for patrons.

**Figure 41. Damage to Vegetation**

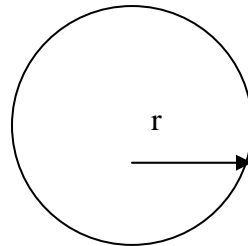
### 5.4.2 Calculating the Area of a Parking Lot or Sidewalk

In order to know the total amount of de-icing chemical to apply the area being treated should be calculated. For a parking lot or sidewalk use either a scaled map, available from the property owner, or actual measurement. Knowing the area along with the pavement temperature will allow use of the application charts above.

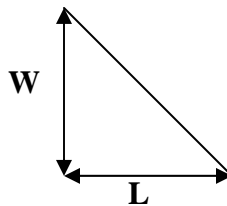
The area or square feet of a square or rectangle is **Length (L) x Width (W)**



The area or square feet of a circle is **3.14 x ( r x r )** where the radius ( r ) is half the distance across the circle



The area or square feet of a right triangle is **Length (L) x Width (W) divided by 2**



**Always remember to:**

**Plow or shovel before applying chemical**

**Use the proper application rate for the condition**

To calculate the total amount of chemical needed multiply the application rate (from the guidelines chart) by the area and divide it by 1,000 sq.ft. The result is the total chemical needed for your application area.

**Example:** a parking lot area of 100,000 sq.ft. with an application rate of 3 lbs/1000sq.ft.  $100,000 \times 3 = 300,000 / 1000 = 300$  lbs of chemical (six 50 lb bags).

## 5.5 Evaluate: Review of Activities for Subsequent Operations

Assessing practices and treatment activities post-storm can help inform subsequent operational decisions. Document events in a storm data collection system and keep it accessible for review as needed. The following information should be considered: weather conditions, pavement conditions, treatment type and time, plowing activities, treatment quantity, observed risk areas, accidents, environmental impact and input from others in the community.

### Summary of Key BMPs

**Plow, shovel, blow:** Use mechanical means by which to remove snow and ice prior to using chemical control.

**Calibrate:** Calibrate equipment annually to know how much material is being applied. Keep calibration records in your vehicle for proper spreader settings.

**Correctly apply:** The right chemical at the right time under the right conditions. Adopt new technologies such as ground speed oriented control and follow reduced application rates.

**Pre-wet salt:** The application rate drops by 30 percent if salt is pre-wetted, it works faster and stays in place longer.

**Anti-ice:** liquid brine applied before the storm will prevent ice from bonding to the pavement allowing for less chemical use and less operator time.

**Don't mix salt and sand:** They work against each other. Salt is for melting and sand is an abrasive for use on top of ice.

**Storage:** Make certain all salt piles are under cover and prevent water runoff.

**Training:** stay up to date on current snow and ice treatment methodologies and technologies.

## 5.6 Estimated Percent Chloride Reduction Potential by BMP Type

Estimated percent reductions outlined in the matrix below are dependent on many factors. Weather severity, road surface condition, equipment type, proper calibration of equipment, operator skill and training level all contribute to the success of efficiently and effectively using chlorides within impaired watersheds.



Table 9 outlines recommended practices in which information is most readily available for achievable reductions without decreasing the level of service. Estimated reduction percentages were derived from a combination of literature review, information provided by equipment manufactures, and other states' experience implementing reduction programs.

**Table 9. Recommended Chloride BMPs**

Chloride Reduction BMPs	Definition	Potential % Chloride Reduction
Pre-Wetting	Application of salt brine or proprietary chemical to dry salt as it is being applied to the roadway	20% - 30%
Pre-Treating	Application of salt brine or proprietary chemical to dry salt either before, during, or after it has been loaded into the truck.	10% - 30%
Anti-Icing	Application of salt brine or proprietary chemical up to 48 hours in advance of onset of storm.	10% - 30%
Zero-Velocity Spreaders	Spreader ejects salt particles at the same velocity of the forward motion of the truck's traveling speed; allowing salt to drop as if the spreading vehicle was standing still.	10% - 50%
Groundspeed Oriented Spreader Controls	Allows accurate dispensation of prescribed salt application rates irrespective of vehicle speed. Controls can be integrated to automatically vary application rate with ground temperature. Controller units can integrate GIS and wirelessly download application rate data for review	10% - 30%*
Equipment Calibration	Ensures equipment application of chlorides is accurate	5-20%
In-Cab Air/Ground Temp. Sensor	Installation of pavement and air temperature sensors with in-cab readout.	1% - 10%*
Training, improved storage and handling practices	Training staff about various best management practices, improving storage and handling practices for loading and unloading salt	10%-25%*

*Note % reductions assumed do not take into account existing practices*

\* highly dependent on existing procedures and level of adoption

## **Section 6. Additional Recommendations for Chloride Reduction**

### **6.1 Procedural/Operational Training Programs**

In addition to training supervisors and staff that deal directly with snow and ice management tasks it is also important to provide training to police officers and emergency responders. There has been a direct correlation between not being able to “see” deicing materials on the roadway with the assumption that the roadway has not been treated. Often, the roadway has already been treated, but the deicing material applied may not have had a chance to begin working. Or, the truck may not yet have reached that part of its route.

It is suggested that yearly pre-winter meetings be held with the New Hampshire Department of Safety, police officers and other emergency responders that are working together to keep roadways safe during the winter season. Pre-winter meetings can be an opportunity to provide information about the level of service and the methods used to manage snow and ice removal on various types of roads.

The University of New Hampshire Technology Transfer Center (T<sup>2</sup>) in cooperation with NHDES, NHDOT, FHWA, and USEPA has established training programs in winter maintenance for state, municipal and private sector operators. T<sup>2</sup> has expanded winter maintenance offerings for State and municipal operators participating in the Roads Scholar Training Program, and created a new certification program for salt applicators. The training provides information on the environmental impacts of chlorides and how to efficiently use best management practices to obtain reductions while maintaining safe driving conditions. Training sessions run from half day to full day and include workshops for supervisors, operators, parking lot and private road attendants with various topics, classroom discussion and hands on learning. Training time is eligible for Professional Development Hours and Continuing Education Units through the University of New Hampshire. Participants receive certification upon successful completion of Level I training.

### **6.2 Revisions to Planning and Site Plan Review Process**

Preventing environmental problems before they occur is the most cost-effective and productive way to plan for the future. Municipalities are empowered to regulate land use through zoning, subdivision, and site plan review regulations.

To reduce the need for salt created by development and redevelopment, municipal site plan review regulations could require that parking lots be constructed and situated to minimize salt application. Parking space requirements should be minimized. Construction techniques should include porous pavement or other technologies that reduce the need for salt. Siting requirements should incorporate access to sunlight, and slope and curve limitations.

Future population growth and increased commercial development is expected in the vicinity of the I-93 corridor. Growth will accelerate the use of chloride deicing chemicals, and the TMDL does not include additional allocation for future private roads and parking lots. An allowance for increased development including roads and parking lots can be included in future implementation plans. Consensus for salt allocations among the owners of road and parking lot systems needs to be mutually agreed on.

### **6.3 Liability Protection from Slip and Fall Claims**

A major obstacle to salt reduction voiced by private sector representatives is concern for increased liability due to salt reduction practices. In addition, the profession currently lacks formal training programs for snow and ice removal operators.

The private sector is a critical partner in achieving salt load reduction. In response to these concerns, in 2010 DES requested a bill that would provide liability protection and create a certification and training program for commercial salt applicators. The bill was referred for interim study by the House Resources Recreation and Development Committee, which recommended the bill for future legislation. A new bill was filed for the 2011 session.

In conjunction with supporting certification and training programs, private applicators should use the best management practices outlined in this manual with special focus on documentation of all storm events and winter maintenance activities in cases of slip and fall claims. Interest and participation in training activities, meetings, and work groups is highly recommended.

### **6.4 Addressing Driver Behavior and Expectations**

A common concern expressed by highway maintainers and public safety officials is that drivers have an unrealistic expectation of clear roads at all times during the winter. This expectation leads to unsafe driving behavior, where drivers are moving too fast for road conditions and do not allow time for public works crews to do their jobs.

The I-93 Salt Reduction Work Group expressed a desire to allocate some of the federal funds available for salt reduction to the regional need to address driver behavior. As a result \$200,000 has been set aside for this purpose and a consulting firm with expertise in community based social marketing was selected for the work.



**Figure 42. Message Board Posting**

A social marketing campaign using specific motivating messages and tools to get past barriers to changing expectations or behaviors related to surface treatment and winter driving in New Hampshire is under way. The program is being designed based on previous research and recommendations summarized from *Potential Solutions for Reducing Road Salt Use in New Hampshire: A Report to the I-93 Salt Reduction Workgroup*, and additional suggestions from workgroup members. Goals of the project include:

- 1) Altering existing public expectations and demand for state and local road and public and private parking lot winter maintenance including changing the perception that bare pavement is necessary during storm events and educating the driving public about the issues surrounding excessive salt use and the environment.
- 2) Building support for and implementation of behavior change programs to assist with voluntary and mandatory approaches for the driving public including decreased snow speed limits, possible decreased winter speed limits, and incorporating winter driving expectations and safety into public and commercial driver education programs.

DOT is planning an Intelligent Travel System (ITS) for the I-93 corridor that will bring real-time road condition information to drivers to promote lower vehicle speed and to encourage safer driving habits. The long term objective is to help change driver behavior and expectations during poor road conditions and especially during severe winter weather.

The DOT Public Information Office and Bureau of Highway Maintenance are working together to establish an ongoing public awareness program. The program will integrate environmental concerns into public messaging about winter maintenance operations.

## **Section 7. Implementation Schedule & Assessment of Progress**

The town of Windham and DOT are responsible for tracking and reporting salt use to DES for each fiscal year for their operations. Tracking and reporting of private sector salt use is currently not regulated and therefore is only obtained by individual private sector applicators willing to share data. DES will annually track the salt imports to the watershed, the percent reduction goal and the number of violations until the water quality standards for chloride have been met at station I93-DIN-01.

Because winter weather conditions vary from year to year, the process for determining compliance with TMDL load allocations will involve a 10-year running average, with estimates of compliance for any given year to be normalized from the Winter Severity Index (WSI). This process will be used to determine compliance for all sectors, and for individual properties or roads within sectors, in the event that becomes necessary.

Assuming that the WSI is random and averages out over 10 years, the 10-year average salt allocation for each sector will be met if the salt use in any given year is less than or equal to the percent of the 10-year allocation predicted from this WSI relationship. This relationship will be assumed to be valid for all roads and parking lots. The measure of salt reduction success will be a rolling 10-year average of salt use relative to the official sector allocations. For information on performance during individual years, the official sector allocations will be adjusted using the relative percent difference between the Winter Severity Index for the year and the average Winter Severity Index for FY01-FY10 (-21.2). For example, if the Winter Severity Index for a year were 30 percent higher than the average, the allocations would be increased by 30 percent to evaluate salt use during that year.

In addition, the Quality Assurance Project Plan outlines that specific conductance and water temperature will be monitored at 15-minute intervals with data loggers and chloride testing will be conducted every six weeks at the outlet station for the watershed, from July 1, 2007 to June 30, 2016. Stream flow will be estimated using regression relationships with the USGS Beaver Brook gage. The data will be analyzed annually by DES for violations of the acute and chronic water quality standards and the percent reduction for critical conditions (NHDES Dinsmore Brook Chloride TMDL, April 2008). Trend analysis reports will be issued in the fall of 2011 and 2016.

It is reasonable to assume that the percent chloride reductions shown in Table 10 can be achieved by 2016 if BMPs listed in Table 9 are fully implemented.

**Table 10. Dinsmore Brook Chloride TMDL Implementation Schedule**

Timeframe	% Chloride Load Reduction
Short-Term (1-2 Years)	5%
Mid-Term (3-7 Years)	25%
Long-Term (8-10 Years)	49%

**Table 11. Chloride Reduction Implementation Plan Matrix**

Objective: Creation of Educational Manuals, Training Programs and Procedural/Operational Strategies		Completion Date of Responsible Agencies							
		DES	UNH	DOT	Windham	LER	RPC	PS	DOS
1	State Snow and Ice BMP Manual for Roadways	2012		2012					
2	State Snow and Ice BMP Manual for Parking Lots	2012		2012				2012	
3	Develop DOT Winter Maintenance Training Program for Salt Reduction			2012					
4	Certification Training Program for Private Sector		2011						
5	Training and Certification Program for Municipal Staff		2011		2011				
6	Legislative approval of salt applicators license program	DLA							
7	Legislative approval of mandatory use of snow tires								DLA
8	Develop Joint Incident Protocols			2011					2011
9	Complete Driver Behavior Study	2012							
10	Adopt traffic violation procedure to address reckless driving during inclement road conditions								DLA
11	Develop winter driving training and require attendance for repeat traffic violation offenders								DLA
12	Develop training for inexperienced drivers, such as high school students				2012				2012
13	Reduce driving speed limits during inclement weather conditions			2010	2010				
14	Hold prewinter meetings to review Level of Service				2011	2011			
15	Develop call-back ranking system				2012	2012			
16	Develop and adopt a formal snow and ice removal policy				2011				
17	Revise site plan review process to include designs and/or management strategies that may decrease chloride use				2012		2012		
18	Revise permit review process to include designs and/or management strategies that may decrease chloride use	2012							
19	Creation of a salt reduction ordinance				2015				
20	Require mandatory training for employees and contracted staff that deal with winter maintenance			2012	2012			2012	
21	Review and update Salt Management Plans every 5 years				2015				
22	Development of company operational procedure manual for snow and ice removal							2015	
23	Develop record keeping strategy for salt application			2012	2012			2012	

24	Properly store salt under cover and on an impervious surface and away from surface water			2011	2011			2011	
----	--	--	--	------	------	--	--	------	--

Objective: Snow and Ice Removal BMP Applications		Completion Date of Responsibly Agencies							
		DES	UNH	DOT	Windham	LER	RPC	PS	DOS
1	Modify existing equipment for prewetting				2012			2012	
2	Implement prewetting watershed wide			2014	2014			2014	
3	Implement anti-icing watershed wide			2016	2016			2016	
4	Use handheld or truck mounted spreaders			2011	2011			2011	
5	Install ground speed oriented spreaders to trucks			2014	2014			2014	
6	Use alternative snow fighting methods such as snow fences where applicable			2011	2011			2011	
7	Manage overflow parking areas based on level of use			2013				2013	
8	Properly maintain and calibrate equipment			2011	2011			2011	
9	Complete periodic inspections of parking lots and walk ways for over application of deicer. Follow up with staff/contractor on findings.							2012	
10	Adopt BMP's at all salt storage and handling facilities			2012	2012			2012	
11	Track salt use utilizing salt accounting system developed by UNH T2							2012	
12	Install AVL systems to collect real time data			2015	2015				

*DES- Department of Environmental Services, DLA- Dependant on Legislative Approval, DOS- Department of Safety, DOT- Department of Transportation, LER- Local Emergency Responders, PS- Private Sector, RPC- Rockingham Planning Commission, UNH T2- University of New Hampshire, Technology Transfer Center, Windham- Town of Windham*

Five years after the publication of this Implementation Plan, DES will review the water quality and salt usage data to document what progress towards meeting the TMDL has been achieved. If the progress is insufficient, DES will reconvene the stakeholders and change the Implementation Plan.

## **Section 8. References**

American Association of State Highway and Transportation Officials (AASHTO), *Environmental Stewardship Practices, Procedures and Policies for Highway Construction and Maintenance, 2004.*

Boselly, S.E., J.E. Thornes, C. Ulberg, and D. Ernst., *Road Weather Information Systems, Volume 1: Research Report*, Report SHRP-H-350, SHRP, National Research Council, Washington, DC, 1993.

Boselly, S.E. and D. Ernst *Road Weather Information Systems, Volume 2: Implementation Guide*, Report SHRP-H-351, SHRP, National Research Council, Washington, DC 1994.

City of Hamilton New Jersey, PowerPoint Presentation: *Implementing an Anti-Icing Policy at the Municipal Level, 2007*

Federal Highway Administration, *Manual of Practices for an Effective Anti-icing Program: A Guide for Highway Winter Maintenance Personnel, 1996.*

Jeffrey H. Taylor & Associates and The Center for the Environment, Plymouth State University, *Potential Solutions for Reducing Road Salt Use in New Hampshire: A Report to the I-93 Salt Reduction Workgroup*, February 2008.

Kelting, D. and Laxson, C., *Review of Effects and Costs of Road De-Icing with Recommendations for Winter Road Management in the Adirondack Park*, Adirondack Watershed Institute Report #AWI2010-01, February 2010.

Minnesota Department of Transportation, *Minnesota Snow and Ice Control: Field Handbook for Snowplow Operators, 2005.*

Minnesota Department of Transportation, *Winter Parking Lot and Sidewalk Maintenance Manual: Reducing Environmental Impact of Chloride*, June 2008.

Nantung, Tommy., *Evaluation of Zero Velocity Deicer Spreader and Salt Spreader*, 2001. Available at <http://docs.lib.perdue.edu/jtrp/95>

National Cooperative Highway Research Program, Report 526. *Snow and Ice Control: Guidelines for Materials and Methods*, Transportation Research Board. 2004.

National Cooperative Highway Research Program, Report 577: *Guidelines for the Selection of Snow and Ice Control Materials to Mitigate Environmental Impacts*, Transportation Research Board, 2007.



New Hampshire Department of Environmental Services(NHDES), Fact Sheet WD-DWGB-22-30. *Storage and Management of Salt Deicing Materials*, 2010.

New Hampshire Department of Environmental Services (NHDES), Fact Sheet WD-WMB-3, *Snow Disposal Guidelines*, 1997.

New Hampshire Department of Environmental Services (NHDES), Total Maximum Daily Load (TMDL) Study for Waterbodies in the Vicinity of the I-93 Corridor from Massachusetts to Manchester, NH: Dinsmore Brook in Windham, NH., April, 2008.

New Hampshire Department of Transportation (NHDOT), *Salt Management Plan*(Draft), March, 2010.

New Hampshire Department of Transportation (NHDOT), *Winter Maintenance Snow Removal and Ice Control Policy*, October 15, 2001.

New Hampshire Department of Transportation(NHDOT), *Implementation Plan to Increase the Efficiency and Effectiveness of Road Salt Use to Meet Total Maximum Daily Load for Chloride*,2009.

New York State Department of Transportation (NYSDOT), *Equipment Operator Snow and Ice Manual*, Highway Department, 2007.

New York State Department of Transportation (NYDOT), *Highway Maintenance Guidelines: Snow and Ice Control*, August, 2006.

O'Keefe and Shi, *Synthesis of Information on Anti-icing and Prewetting for Winter Highway Maintenance Practices in North America*, 2005.

Strategic Highway Research Program, National Research Council, *Development of Anti-Icing Technology*, Washington D.C., 1994.

The Salt Institute, *The Snow Fighters Handbook – A Practical Guide for Snow and Ice Manual*, Highway Maintenance Division, 2007.

Town of Windham, New Hampshire, *Salt Reduction Plan*, June, 2010.

United States Environmental Protection Agency (USEPA), *The Clean Water Act (CWA)*, United States Federal Government, 2002. Available at <http://www.epa.gov/lawsregs/laws/cwa.html>

United States Environmental Protection Agency (USEPA), *Source Water Protection Practices Bulletin: Managing Highway Deicing to Prevent Contamination of Drinking Water*, August 2010.

United States Environmental Protection Agency (USEPA), *Technical Support Document for Water Quality-based Toxics Control*. EPA/505/2-90-00, March 1991

United States Environmental Protection Agency (USEPA), *Groundwater Protection Action Plan, Section 8: Winter snow and Ice Operations*, October 2009.

University of Maine, *Maine Winter Roads: Salt, Safety, Environment and Cost*.

University of New Hampshire Technology Transfer Center, *Manual of Practices for Anti-icing of Local Roads*, 1996.

University of New Hampshire Technology Transfer Center, *Salt Reduction Compliance for Supervisors*, Workshop October 2010.

Wisconsin Transportation, *Pre-wetting and Anti-Icing-Techniques for Winter Road Maintenance*, Bulletin No. 22

Wenck Associates, Inc. and The Shingle Creek Water Management Commission, *Shingle Creek Chloride TMDL Implementation Plan*, February, 2007.

Williams, D. *Past and Current practices of Winter Maintenance at the Montana Department of Transportation* (MDT), Montana Department of Transportation, 2001.

**Section 9: Appendices**



**WINTER MAINTENANCE  
STORM LOG**

<b>Date:</b>			<b>Crew:</b>		<b>Storm #:</b>	
<b>1. TIME</b>			<b>Day of Week</b>			
Storm Start:			10-01:			
Storm End:			10-02:			
Road Cleared:						
<b>3. DESCRIPTION</b>						
<b>Precipitation</b>		<b>Temperature</b>		<b>Wind</b>		<b>Visibility</b>
Type:		Max:	Calm	<input type="checkbox"/>	Good	<input type="checkbox"/>
Depth (in)		Min:	Breeze	<input type="checkbox"/>	Fair	<input type="checkbox"/>
Drifts (ft)			Gale	<input type="checkbox"/>	Poor	<input type="checkbox"/>
<b>4. PROCEDURES</b>				<b>5. RESULTS</b>		
<b>Action</b>	<b>Lane Miles</b>	<b>Time</b>		<b>Excellent</b>	<b>Good</b>	<b>Poor</b>
Salt	<input type="checkbox"/>	From:	To:	<input type="checkbox"/>	<input type="checkbox"/>	<input type="checkbox"/>
Plowing	<input type="checkbox"/>	From:	To:	<input type="checkbox"/>	<input type="checkbox"/>	<input type="checkbox"/>
Abrasives	<input type="checkbox"/>	From:	To:	<input type="checkbox"/>	<input type="checkbox"/>	<input type="checkbox"/>
Other		From:	To:	<input type="checkbox"/>	<input type="checkbox"/>	<input type="checkbox"/>
<b>6. MATERIALS</b>						
<b>Type</b>	<b>Tons</b>	<b>Comments</b>				
Salt						
Abrasives						
Other						
<b>7. COMMENTS</b>						
<b>7. COMPLETED BY</b>						
<b>NAME:</b>				<b>TITLE:</b>		



# Hydraulic-Run Spreader Calibration

NH Best Management Practices

## WHY CALIBRATE?

You can't reduce your salt use if you don't know how much salt you actually use! The goal of calibrating is to know how much material you are putting down on a roadway or parking lot for every setting on your truck that you use. This is why calibrating your equipment is the first step to reducing salt use and saving money!

## REMEMBER:

Each truck must be independently calibrated for each material it will be used to spread (the salt calibration chart will be different than the sand calibration chart).

Calibrations should be performed annually, or after a spreader is serviced.

## CALCULATIONS:

There are a few simple calculations you must perform in order to complete the calibration.

Once all of the necessary data is recorded, head back inside and warm up! Refer to the reverse side of this fact sheet for calculation instructions.



## Step 1: Load the Truck

Partially load the truck. Half of a full load should be more than adequate for calibration purposes.

## Step 2: Set Your Controls

**Gate Height:** Set the gate height to its lowest practical setting (~2"). This should be kept constant throughout the calibration process. If you find that not enough material is dispensed with this setting, try 2.5" to 3".  
**Engine Speed:** Warm the truck up and run the engine at the typical rate seen during spreading (approximately 2000 rpm).



## Step 3: Measure Spread Width

Measure the width that the material covers during spreading. Do this for each conveyor/auger setting you are calibrating. Round your numbers to the nearest half foot and record them in column "W" of the calibration chart (see reverse side).

## Step 4: Collect & Weigh Material

You will need either a sheet of canvas, a tarp, or a bucket to collect the material that is dispensed from the spreader, as well as a scale. Weight the object you are using to collect the material in, and record that value in the purple box above the discharge rate column. Collect material for 1 minute. Weigh the collected material and subtract the weight of the tarp/canvas/bucket. Record this value in the first purple column of the calibration chart. Do this 3 times for each conveyor/auger setting that is typically used. Average these three values together and record in the orange column in the calibration chart.



## Step 5: Perform Calculations

Go inside and calculate your discharge rate using the calibration chart for each truck speed and conveyor/auger setting you normally use. Refer to the reverse side of this fact sheet for calculation instructions. The formula you will be using is shown below:

$$D = \frac{B \times C}{A}$$

## Step 6: Distribute Completed Calibration Cards!

Put a copy of the calibration chart in the truck you just calibrated. Also, leave a copy of the calibration chart in the office so you have a copy in case the original is damaged.



# Calibration Chart (Hydraulic Type)

Material: \_\_\_\_\_ Truck/Spreader ID: \_\_\_\_\_

Date: \_\_\_\_\_ Performed by: \_\_\_\_\_

Tarp/Canvas/Bucket Weight:

Conveyor or Auger Setting	W	A	Discharge Rate (lb/min.)			B	D						
	Spread Width (ft.)	5.28 × W	Run 1	Run 2	Run 3	Average Discharge Rate ((Run1 + Run2 + Run3)/3)	Pounds of Material Discharged per 1000 square ft. (D = B × C ÷ A)						
							5 mph (C = 12)	10 mph (C = 6)	15 mph (C = 4)	20 mph (C = 3)	25 mph (C = 2.4)	30 mph (C = 2)	
1													
2													
3													
4													
5													
<b>EX</b>	14	5.28 × 14 = 73.92	87	92	93	(87+92+93)÷3 = 90.67	12 × 90.67 ÷ 73.92 = 14.72	6 × 90.67 ÷ 73.92 = 7.36	4 × 90.67 ÷ 73.92 = 4.91	3 × 90.67 ÷ 73.92 = 3.68	2.4 × 90.67 ÷ 73.92 = 2.94	2 × 90.67 ÷ 73.92 = 2.45	

**Calculation Instructions:** Multiply the spread width from column **W** by **5.28** and record the answer in column **A**. For each conveyor/auger setting, add **Run 1**, **Run 2**, and **Run 3** together. Divide the result by **3** and record in column **B** to get the average discharge rate. To find the pounds of material discharge per 1000 square feet, you must know the number of minutes it takes to travel one mile at every truck speed you intend to calibrate for. These numbers are designated as variable "**C**". The "**C**" value for each travel speed is shown in red under that given speed. Multiply column **B** by the "**C**" value for that speed and divide by the **A** column to find the number of pounds of material discharged per 1000 square feet for the given speed. Record these numbers in the **D** columns. The full equation is shown here:

$$D = \frac{B \times C}{A}$$



# Pony Motor-Run Spreader Calibration

NH Best Management Practices

## WHY CALIBRATE?

You can't reduce your salt use if you don't know how much salt you actually use! The goal of calibrating is to know how much material you are putting down on a roadway or parking lot for every setting on your truck that you use. This is why calibrating your equipment is the first step to reducing salt use and saving money!

## REMEMBER:

Each truck must be independently calibrated for each material it will be used to spread (the salt calibration card will be different than the sand calibration card).

Calibrations should be performed annually, or after a spreader is serviced.

## CALCULATIONS:

There are a few simple calculations you must perform in order to complete the calibration.

Once all of the necessary data is recorded, head back inside and warm up! Refer to the reverse side of this fact sheet for calculation instructions.



## Step 1: Load the Truck

Partially load the truck. Half of a full load should be more than adequate for calibration purposes.

## Step 2: Set Your Controls

**Gate Height:** Set the gate height to its lowest practical setting to start (approximately 1" to 1.5"). After the truck is calibrated for the lowest gate setting, calibrate for each 1/2" increment greater than the lowest setting. Continue until all gate settings you use are calibrated.

**Engine Speed:** Set the pony motor speed to the maximum setting, or to the setting you would normally use.



## Step 3: Measure Spread Width

Measure the width that the material covers during spreading. Do this for each gate setting you are calibrating. Round your numbers to the nearest half foot and record them in column **W** of the calibration chart (see reverse side).

## Step 4: Collect & Weigh Material

You will need either a sheet of canvas, a tarp, or a bucket to collect the material that is dispensed from the spreader, as well as a scale. Weigh the object you are using to collect the material in, and record that value in the purple box above the discharge rate column. Collect material for 1 minute. Weigh the collected material and subtract the weight of the tarp/canvas/bucket. Record this value in the first purple column of the calibration chart. Do this 3 times for each gate opening that is typically used. Average these three values together and record in the orange column in the calibration chart.



## Step 5: Perform Calculations

Go inside and calculate your discharge rate using the calibration chart for each truck speed and gate setting you normally use. Refer to the reverse side of this fact sheet for calculation instructions. The formula you will be using is shown below:

$$D = \frac{B \times C}{A}$$

## Step 6: Distribute Completed Calibration Cards!

Put a copy of the calibration card in the truck you just calibrated. Also, leave a copy of the calibration card in the office so you have a copy in case the original is damaged.



# Calibration Chart (Pony Motor Type)

Material: \_\_\_\_\_ Truck/Spreader ID: \_\_\_\_\_

Date: \_\_\_\_\_ Performed by: \_\_\_\_\_

Tarp/Canvas/Bucket Weight:

Gate Opening	W	A	Discharge Rate (lb/min.)			B	D							
	Spread Width (ft.)	5.28 × W				Average Discharge Rate ((Run1 + Run2 + Run3)/3)			Pounds of Material Discharged per 1000 square ft. (D = B × C ÷ A)					
			Run 1	Run 2	Run 3	5 mph <span style="color: red;">(C = 12)</span>	10 mph <span style="color: red;">(C = 6)</span>	15 mph <span style="color: red;">(C = 4)</span>	20 mph <span style="color: red;">(C = 3)</span>	25 mph <span style="color: red;">(C = 2.4)</span>	30 mph <span style="color: red;">(C = 2)</span>			
1"														
1.5"														
2"														
2.5"														
3"														
<b>EX</b>	14	5.28 × 14 = 73.92	87	92	93	(87+92+93)÷3 = 90.67	12 × 90.67 ÷ 73.92 = <span style="background-color: yellow;">14.72</span>	6 × 90.67 ÷ 73.92 = <span style="background-color: yellow;">7.36</span>	4 × 90.67 ÷ 73.92 = <span style="background-color: yellow;">4.91</span>	3 × 90.67 ÷ 73.92 = <span style="background-color: yellow;">3.68</span>	2.4 × 90.67 ÷ 73.92 = <span style="background-color: yellow;">2.94</span>	2 × 90.67 ÷ 73.92 = <span style="background-color: yellow;">2.45</span>		

**Calculation Instructions:** Multiply the spread width from column **W** by **5.28** and record the answer in column **A**. For each gate setting, add **Run 1**, **Run 2**, and **Run 3** together. Divide the result by **3** and record in column **B** to get the average discharge rate. To find the pounds of material discharge per 1000 square feet, you must know the number of minutes it takes to travel one mile at every truck speed you intend to calibrate for. These numbers are designated as variable "**C**". The "**C**" value for each travel speed is shown in red under that given speed. Multiply column **B** by the "**C**" value for that speed and divide by the **A** column to find the number of pounds of material discharged per 1000 square feet for the given speed. Record these numbers in the **D** columns. The full equation is shown here:

$$D = \frac{B \times C}{A}$$

WD-DWGB-22-8

2010

## Holding Tanks for Floor Drains

Holding tanks that receive wastewater from floor drains in areas where regulated contaminants<sup>1</sup> are used or stored or that will receive non-domestic, non-hazardous wastewater must be registered with the Water Division of DES under New Hampshire Administrative Rules Env-Wq 402.35, "Holding Tank Registration for Discharges of Non-domestic, Non-hazardous Wastewater."

### What Are DES's Requirements for Holding Tanks?

- The minimum holding tank capacity must be 1,000 gallons.
- Holding tanks and piping must be watertight and sealed with materials compatible with the liquid or sludge being stored.
- Access must be provided to each compartment of the tank for inspection and cleaning by means of either a removable cover or manhole (minimum diameter 20 inches). Manholes must extend to finished grade.
- The tank must be designed for the expected maximum structural load and ballast must be provided when necessary to prevent structural damage when the tank is emptied.
- The volume between inlet cover and the maximum water depth must be equal to approximately 20 percent of the liquid volume stored below the maximum water depth. An alarm with both visual and audio signals must be activated once the water level reaches the maximum water depth.
- The holding tank must be registered with DES. Use the form at [http://des.nh.gov/organization/divisions/water/dwgb/dwspp/gw\\_discharge/documents/holdreg.pdf](http://des.nh.gov/organization/divisions/water/dwgb/dwspp/gw_discharge/documents/holdreg.pdf).
- Records of pumping events shall be kept and made available for review if requested by DES.

### For Additional Information

For additional information, please contact the Drinking Water and Groundwater Bureau at (603) 271-2513 or [dwgbinfo@des.nh.gov](mailto:dwgbinfo@des.nh.gov) or visit [www.des.nh.gov](http://www.des.nh.gov), click on A-Z List and choose Groundwater Discharges. The "Holding Tank Registration Form" can also be found here. All of the bureau's fact sheets are online at <http://des.nh.gov/organization/commissioner/pip/factsheets/index.htm>.

Note: This fact sheet is accurate as of June 2010. Statutory or regulatory changes or the availability of additional information after this date may render this information inaccurate or incomplete.

---

<sup>1</sup> **What is a Regulated Contaminant?** State law defines a regulated contaminant as "any physical, chemical, biological, radiological substance or other matter, other than naturally occurring substances at naturally occurring levels, in water which adversely affects human health or the environment." Consult the Material Safety Data Sheets (MSDSs) for the products you use; see the disposal information in the "Spills or Leaks" section of each MSDS.





# Anti-Icing

NH Best Management Practices

## GET OUT EARLY

Typically anti-icing is most effective if applied 1-2 hours before the precipitation begins however it can be applied up to 24 hours in advance.

## TRY IT FIRST

Trying anti-icing for the first time? Make a 23.3% brine solution and before a storm spray pavement on your own property using a masonry/ plant sprayer. Use this experiment to determine how best to use it with your clients.

## LEAVE SOME PAVEMENT BARE

It's always best to use stream nozzles instead of fan tip to avoid creating a slippery condition. If the anti-icing liquid freezes the bare pavement will still provide a traction surface.

## USE A FILTER

Having a filter in your liquid dispensing system will reduce clogs in your nozzle. Automotive in line fuel filters work quiet well. If your liquid dispenser is not functioning properly be sure to check the filter first.

## A Proactive Treatment

Anti-icing before a storm is very similar to using a non-stick spray on a pan before cooking. Just like a non-stick spray prevents food from bonding to the pan, anti-icing prevents snow and ice from bonding to the pavement so that it can be plowed away. Anti-icing can save you **money** as it costs 50% less than reactive deicing.



## Make Your Own Salt Brine

When making brine it is important to add enough salt to produce a 23.3% solution which freezes around 0°F. Roughly 2.5lb per gallon of water will produce a 23.3% solution. You can verify using a salometer (~\$20) a 23.3% solution will have a specific gravity of 1.176, or 85% salinity. Consult the Brine Making BMP sheet for more info.

## How Much Should I Use and When?

You can apply brine up to 24 hours in advance of the storm. Typical application rates range from 0.5 to 0.75 gallon per 1000 sq.ft. (10' x 100' area). Other chemicals such as magnesium are also available—consult your supplier for application rates. Anti-icing is **not** advised prior to freezing rain events.



## Getting Started

Try making your own salt brine by putting 13 lb of salt in 5 gallons of water to get a 23.3% salt brine solution. Mix the brine until all of the salt is dissolved. Using a masonry sprayer apply the liquid several hours before a storm. Start by applying about 0.25—0.5 gallons to a 10' x 50' area. Adjust the application rates based on your experience. Being careful not to over apply and cause a slippery condition.





# How Salt Works

NH Best Management Practices

## BE PROACTIVE - ANTI-ICE

Anti-icing is the proactive method of preventing snow and ice from bonding to pavement. It can be more than 50% more efficient than deicing. See the NH Anti-Icing Factsheet for more information.

## PRE-WETTING FOR FASTER ACTING SALT

Adding brine to salt before you apply it to pavement jump starts the melting process which means your pavement will be clear sooner. See the Pre-wetting Fact Sheet for more information.

## KNOW YOUR LIMITS

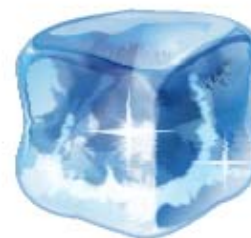
Dry salt becomes ineffective below 15°F if possible wait until the temperature rises before applying salt. At 30°F 1 lb of salt can melt 46.3 lb of ice in 5 minutes. At 15°F 1 lb of salt can melt 6.3 lb of ice in 1 hour.

## PLOW FIRST

Always plow before applying any kind of chemical deicer to avoid pushing it away!

## How Do We Melt Ice?

Ice can be melted by increasing the temperature, or lowering the freezing point of the water. It's not cost effective to use heat to melt ice on our roads so we use chemicals to reduce the freezing point—anything that will dissolve in water will work, including: salt, sugar, even alcohol!

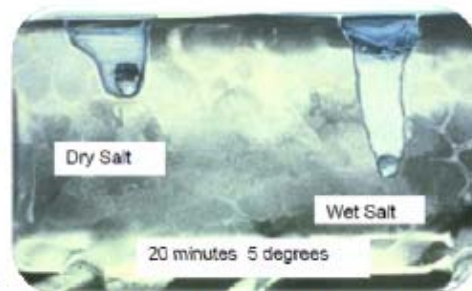


## Why Use Salt?

Salt (Sodium Chloride) is the cheapest and most readily available chemical that efficiently melts ice and can be easily applied to our roadways and parking lots. However salt does corrode our cars and bridges, contaminates drinking water and pollutes our streams. Alternatives include potassium acetate, and calcium magnesium acetate (CMA), — all of which are considerably more expensive than calcium chloride, and have their own environmental concerns.

## Brine Makes It Happen

The first step in melting ice is the formation of a brine. Salt crystals pull water molecules out of ice formation which creates a brine with a lower freeze point. Once the brine is formed melting is greatly accelerated. Save time and money by pre-wetting your salt with a brine before it hits the pavement to jump start melting! See the Pre-Wetting fact sheet for more information.



Source: Wisconsin DOT Transportation Bulletin #22



## Save \$\$ and the Environment

In New Hampshire there are over 40 watersheds currently contaminated from road salt. As the pavement temperature drops more salt is required. As the pavement temperature rises less salt is required. Save money and the environment by using only what is needed to do the job. See NH application rate charts for recommended rates.



WD-WMB-4

2011

## Road Salt and Water Quality

The amount of snowfall in New Hampshire and the necessity of overland travel require winter snow and ice management by the state, the municipalities, and the private sector. Deicing materials are often used in order to keep the public safe during these winter weather events. The most commonly used de-icing chemical is sodium chloride (NaCl) also known more commonly as road salt. Road salt is relatively inexpensive with an average cost of \$50 - \$60 per ton. Road Salt is readily available and easy to handle, store, and spread. Its purpose is to reduce the adherence of snow and ice to the pavement, preventing the formation of hard pack. Once hard pack forms, it is difficult to remove by plowing alone.

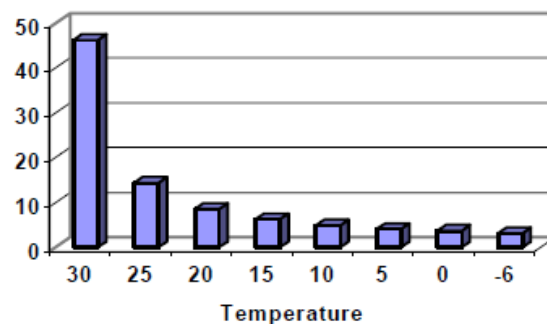
In the United States from 2005-2009 an average of 23 million tons of salt were applied to our roads, parking lots, sidewalks and driveways each year.<sup>1</sup> Studies have shown that, in urbanized areas, about 95 percent of the chloride inputs to a watershed are from road and parking lot deicing. In four impaired watersheds in the southern I-93 corridor of New Hampshire, road salt sources were 10-15 percent from state roads, 30-35 percent from municipal roads, and 45-50 percent from private roads and parking lots.

### How Salt Works

The first step in melting ice is to lower its freezing point. This is done through the formation of brine where salt crystals pull water molecules out of ice formation. Once the brine is formed, melting is greatly accelerated. The rate at which melting occurs is dependent on the temperature. Sodium chloride loses its effectiveness (has difficulty going into solution) when temperatures fall below 15° F. Applications below this

temperature, even at high rates, will not result in significant snow or ice melting; therefore, it is critical to know the current and expected temperature range of the winter weather event.

Pounds of Ice Melted per Pound of Salt



Graph obtained from The Salt Institute FY03 Snow & Ice Fact #20

### What Happens to Salt in the Environment

The applied salt dissolves into 40 percent sodium ions (Na<sup>+</sup>) and 60 percent chloride ions (Cl<sup>-</sup>) in the melting snow and ice and make their way into our environment.

<sup>1</sup> U.S. Geological Survey, Mineral Commodity Summaries, January 2010

**Chloride(Cl<sup>-</sup>):** Chloride is highly soluble, very mobile, and its density allows for it to settle to the bottom of a waterbody. Chloride is toxic to aquatic life at levels above 230 mg/l, which is the state water quality standard. There is no natural process by which chlorides are broken down, metabolized or taken up by vegetation. In 2008, New Hampshire listed 19 water bodies impaired by chloride; in 2010 that number increased to 40. Trends show that chloride levels continue to rise with increasing use of road salt. Although chloride does not pose a human health concern, it can affect the taste of drinking water.

**Sodium (Na<sup>+</sup>):** The transport of sodium in the environment is not as prominent as chloride due to ion exchange; however, this exchange can alter the soil chemistry by replacing and releasing nutrients such as calcium, magnesium and potassium into the groundwater and surface water. This can lead to increased nutrient concentrations and affect the ability of the water to buffer acid deposition impacting the aquatic environment. Contamination of sodium in drinking water is a concern for individuals restricted to low-sodium diets due to hypertension (high blood pressure). The USEPA has set an advisory limit for drinking water for public water systems at 20mg Na/L to assist doctors in making recommendations for those patients on a salt restricted diet.

**Road Salt Additives:** Additives to road salt like ferrocyanide, which is used as an anti-caking compound in large salt supplies, can have impacts on both the environment and human health due to cyanide ions being released by certain types of bacteria as well as from exposure to sunlight. The USEPA in 2003 added this compound to its list of toxic pollutants under section 307(a) of the Clean Water Act.

### **Road Salt Management Issues**

For many road managers and parking lot maintainers the winter maintenance goal is to obtain bare and dry pavements at the earliest practical time following cessation of a storm for effective regular high speed travel and pedestrian safety. Traffic, volume, speed and gradient are the primary factors in determining the level of winter maintenance service for State and municipal roads. Pedestrian travel along with slip and fall liability are the priority for land owners and private sector operators.

A road manager's duty entails awareness of the current and expected weather events, temperatures, equipment capabilities, de-icing chemical inventories, application rates, driving routes, as well as staffing availability for each winter storm event. Expectations from the driving public, property managers and customers along with balancing the environmental effects of de-icing chemicals makes the job of these managers challenging.

Another concern to road managers, property owners, and to citizens is the damage and cost to infrastructure and vehicles associated with road salt use. Corrosion of concrete reinforcing rods in roads, bridges, parking garages along with the cost of corrosion protection practices for highways and the automobile industry cost a staggering \$16 billion-\$19 billion a year.<sup>2</sup> Road salt alternatives that help reduce the cost to infrastructure and limit the environmental impact are critical.

---

<sup>2</sup> Adapted from Report of the Salt Use Subcommittee to the Commission on the Environment on Road Salt Use and Recommendations City of Madison, Wisconsin December 2006

## **Best Management Practices**

Following best management practices and recommendations can help in effective and efficient use of de-icing materials while reducing the impact and preserving the quality of our freshwaters.

### ***Application of Road Salt***

- Plow, shovel, and blow the snow. Use mechanical means to remove snow, do not use salt or other de-icing chemical to “burn-off” snow and ice.
- Calibrate your equipment. Knowing your equipment is calibrated and the application rate is accurate will save chemical cost and will reduce the environmental impacts. Calibrate annually and keep a record in the vehicle for spreader settings.
- Choose the right material and apply the correct amount. Know the limits of deicing chemicals. Rock salt is not effective at temperatures below 15°F no matter how much is applied. Check application rates given the current weather conditions.
- Use ground speed controls on your spreader. Application rates should correspond with vehicles speed.
- Pre-wet the salt. Adding brine to salt before it is applied will jump start the melting process and help keep the salt in place by reducing bounce and scatter. Pre-wetting salt can reduce application rates by 20 percent. Typical rates are 8-10 gallons of pre-wet liquid to 1 ton of salt.
- For road applications place salt in a windrow near the centerline. Less salt is wasted and traffic will help work the salt into brine and move it to the shoulder of the road.
- Use anti-icing. Be proactive by applying de-icing chemical prior to snow and ice accumulation. It can reduce the amount of chemical needed by 30 percent. Know when to take action; time plowing operations to allow maximum melting by salt before snow is plowed off the road or parking lot.
- Don't mix salt and sand. Salt is for melting and sand is for traction on top of the ice, they work against each other.
- Be familiar with sensitive areas, such as public water supplies, impaired waters and other water sources. Consider designating reduced salt areas or identifying safe alternatives to road salt in these areas.
- Create a winter snow and ice control policy. Outlining your levels of service, application rates, and plowing frequency and practices provide a reference for decision makers and staff.
- Keep a winter storm log. Record storm events, time, application rates, and other important information describing maintenance activities and results.
- Attend training workshops and stay up to date with new technologies and practices.
- For additional information on training, please refer to UNH Technology Transfer Center at <http://www.t2.unh.edu/>

### ***Storage and Handling***

Salt, sand, and snow storage facilities have the potential to cause water pollution due to runoff. For maximum environmental protection, all salt storage facilities and piles should be covered and placed on an impervious surface with adequate drainage controls to prevent runoff. This is also important for sand piles that may contain a small percentage of salt to prevent the pile from

freezing. Take care while loading salt, sand or chemicals and clean up any spills that occur. Snow piles should be kept away from water sources and below areas where salt is stored. Vehicle washing facilities should have proper drainage to avoid discharge into surface and ground waters.

To obtain more information, please see the following DES fact sheets at:  
<http://des.nh.gov/organization/commissioner/pip/factsheets>

- Snow Dumping [WD-WMB-3](#)
- Holding Tanks for Floor Drains [WD-DWGB-22-8](#)
- Wastewater Discharges from Vehicle Washing [WD-DWGB-22-10](#)
- Storage and Management of Salt Deicing Materials [WD-DWGB-22-30](#)

### **Alternatives to Road Salt**

Environmental impact should be considered when selecting any de-icing chemical or product. Many of the road salt alternatives have a relatively short history or limited amount of use. It is unclear what the potential long term impacts will be for many of these chemicals. Ongoing research, data analysis, and documentation in scientific literature of non-corrosive and environmentally friendly chemicals are necessary.

*Calcium Chloride (CaCl)* – is the second most common used chemical, it is available in flake, pellet or liquid. It is effective at lower temperatures with a practical melting temperature of -20°F. In liquid form it can be used to pre-wet salt or applied directly as an anti-icing technique which can help in preventing snow and ice from bonding to the pavement and reduce the application amount needed. Several disadvantages to CaCl include a higher cost, environmental impact due to chloride, corrosive to metal, it can be difficult to handle and store, and can contribute to slippery conditions if applied incorrectly.

*Potassium chloride (KCl)* – is a naturally occurring material (muriate of potash) that also is used as fertilizer. It is available in liquid or crystal with a practical melting temperature of 20°F. It can be damaging to concrete, has environmental impacts due to chloride and can inhibit plant growth and burn foliage.

*Magnesium Chloride (MgCl)* – is available in liquid or crystal form that melts faster than rock salt; it has a practical melting temperature of 5°F. MgCl attracts moisture and can lead to slippery conditions if applied incorrectly. It is corrosive and contributes to the chloride load in our waters.

*Urea* – is used primarily as fertilizer with a practical melting temperature of 25°F. It releases nitrogen into the soil and can lead to a chemical imbalance in water systems due to nutrient loading. Urea is corrosive and breaks down rapidly into ammonia, which is released into the environment.

*Potassium Acetate (KA)* – has a practical melting temperature of -15°F and is biodegradable and non-corrosive. It can cause slick road conditions if applied in excess and can lower oxygen levels in the waterbody. This is a commonly used deicer in the airline industry and is relatively non corrosive.

Appendix F: How Salt Works : DES Fact Sheet Road Salt and Water Quality

*Calcium Magnesium Acetate (CMA)* – is made from limestone and acetic acid. Its lowest practical melt temperature is 20°F. It is less damaging to soils and vegetation, less corrosive to concrete and steel, less toxic to aquatic organisms, and has limited impact on ground water in comparison to road salt. It is much more expensive than road salt but a full cost analysis may show that is it an economically viable choice given its benefits. It is currently being used in environmentally sensitive areas and on bridges prone to salt corrosion.

*Agricultural by-products* – are mostly proprietary to the manufacturer and can be derived from sources such as corn, beet, grain, alcohol, or molasses. These products are not good at melting snow and ice; however, they do slow down the formation of ice crystals by having a lower freezing point. They are less corrosive than conventional materials and in many cases act as tackifiers to keep product on the road surface. These attributes make the product good for anti-icing and pre-treating salt. They do have environmental impacts in aquatic systems due to their organic nature and can lead to biological oxygen demand, heavy metals, and nutrient enrichment by nitrogen and phosphorus in our waters.

#### **For Additional Information**

For more road salt and water quality information, visit the DES New Hampshire Road Salt Reduction Initiative website at <http://des.nh.gov/organization/divisions/water/wmb/was/salt-reduction-initiative/index.htm> or contact the DES Watershed Assistance Section at (603) 271-7889 or [watershed@des.nh.gov](mailto:watershed@des.nh.gov).

For information on road salt and drinking water, see fact sheet “DWGB-3-17 Sodium and Chloride in Drinking Water” at <http://des.nh.gov/organization/commissioner/pip/factsheets/dwgb/documents/dwgb-3-17.pdf>, or contact the Drinking Water and Ground Water Bureau at (603) 271-2513.

Note: This fact sheet is accurate as of December 2010. Statutory or regulatory changes or the availability of additional information after this date may render this information inaccurate or incomplete.



# Brine Making

NH Best Management Practices

## GET THE LOWEST FREEZE POINT

When salt brine is 23% salt (measured with a hydrometer: 1.176, or with a salimeter: 85%) it has the lowest freeze point possible (about 0°F).

## BRINE STORAGE

23% brine solution may be stored outside, however if temperatures get below 0°F the brine may freeze. A circulator pump will reduce the risk of freezing. If possible store brine indoors to eliminate risk of freezing.

## COST OF BRINE

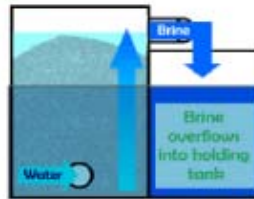
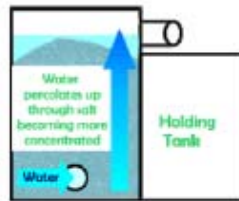
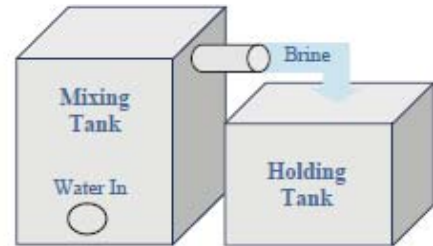
Calcium chloride brine costs about 7¢ / gallon (assuming \$58/ton for salt) after you have your equipment setup.

## MULTIPLE USES

Brine can be used directly for anti-icing, for prewetting salt as it is dispensed from your truck, or to pretreat salt before it is loaded into your truck. Brine can be safely stored for up to a year, however, the concentration should be tested before use.

## What Do You Need?

Brine making is a fairly simple process—the only ingredients are salt and water, and the only equipment you'll need is an open top mixing tank, a holding tank, a small pump, and a salimeter.



Images courtesy of Iowa DOT

## Step 1: Fill Mixing Tank

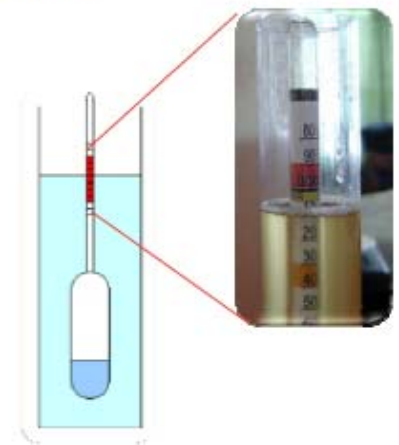
**Add Salt:** Add about 2.5 lb of salt per gallon of water you plan to add. Make sure your mixing tank has a large opening to make adding salt easy.

**Add Water:** Slowly add water from the bottom of your brine mixing tank. This will allow it to percolate up through the salt and overflow into the holding tank.

## Step 2: Check Concentration

Float a hydrometer or salimeter directly in your holding tank and read the value at the surface of the water. The number should be either 85% or 1.176 depending on the units of your device.

If the values are too low, pump some brine from your holding tank back into the mixing tank and allow it to overflow. If values are too high simply add some fresh water



## Quality Control & Documentation

Make sure that you record the date when you create each batch of brine and document who mixed it and checked the concentration. It is also a good idea to note the final concentration. These records should be kept for at least two years to protect your group in the event of litigation.







# Pre-wetting

NH Best Management Practices

## PRE-WETTING?

Pre-wetting is the process of coating a solid de-icer with a liquid before it is spread on a roadway.

## WHY PRE-WET?

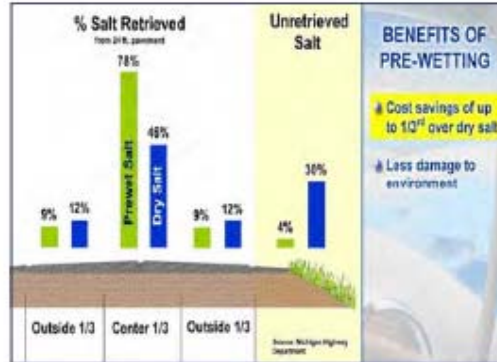
De-icing chemicals must form a brine before they can begin melting ice. Pre-wetting your chemicals accelerates the brine making process, which improves the melting action of the material. Pre-wetting also reduces bounce and scatter of material during spreading, and reduces the total amount of de-icer needed to obtain the desired results.

## REDUCED RATES

If you are pre-wetting, don't forget to reduce your application rates accordingly. Reductions in the range of 15-20% are typical.

## HOW MUCH LIQUID?

A good rule of thumb is to use 8-10 gallons of pre-wetting liquid for every ton of de-icer. For other chemicals, such as magnesium chloride, consult your supplier for application rates



## Pre-wetting Liquids

You have a few options for pre-wetting liquids. The most commonly used is a 23% sodium chloride brine solution. Calcium chloride at 32% solution is also used, as well as Magic Minus Zero™ and other patented products.

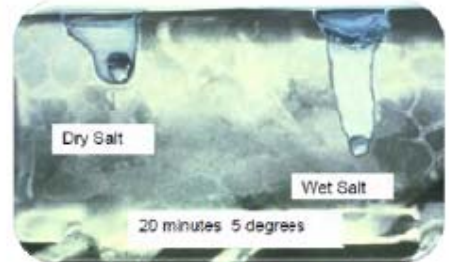
## Spraying the Pile

This is the easiest and most cost effective way to get started in pre-wetting. The first step is to spread your salt pile on a flat, impermeable surface. Next, spray the salt while it is spread out, and mix it around to ensure adequate and consistent liquid coverage. After the salt is sufficiently covered, re-stack the salt in your storage shed for later use.



## Getting Started

Wet the pile! There are two ways to pre-wet your de-icing chemicals. The easiest way to get started with pre-wetting is to spread your salt pile, spray it with pre-wetting liquid, mix it around, and re-pile it. More advanced truck mounted pre-wet systems can be installed on your trucks if you decide to make the investment.



Source: Wisconsin DOT Transportation Bulletin

## Truck Mounted Systems

These systems are mounted in the truck bed and coat the de-icer with liquid as it comes off the conveyor/auger onto the spinner. These systems have the benefit of applying liquid only to the material you use as you use it. However, these systems must be installed on every truck that will be used to spread pre-wetted material.



---

# ENVIRONMENTAL Fact Sheet

---



29 Hazen Drive, Concord, New Hampshire 03301 • (603) 271-3503 • [www.des.nh.gov](http://www.des.nh.gov)

---

WD-DWGB-22-30

2010

## Storage and Management of Salt Deicing Materials

Storage and management of deicing material can be a source of contamination of surface water and groundwater, causing a violation of state water quality standards. These salt-based products dissolve in precipitation and either infiltrate through the ground surface to groundwater, or run off into surface water. Salt that infiltrates the subsurface at significant concentrations can also react with the soils and release metals into groundwater and surface water at concentrations that exceed water quality standards.

The term “deicing material” used here refers to deicing salts, and may include any of the following in either solid or liquid form: sodium chloride (often called rock salt), potassium chloride, calcium chloride, magnesium chloride, and other mixtures that contain salts (chlorides) including mixtures with abrasives, such as sand, cinder, slag, etc.

### Need for Proper Management

Due to their high potential for causing groundwater and surface water pollution, salt storage facilities should not be placed in environmentally sensitive areas. The best strategy to prevent pollution from deicing materials and the associated liability is to use and store these materials responsibly. Facilities should develop good housekeeping practices to minimize loss and waste during the delivery, storage, loading and management of deicing materials.

Existing and new facilities that operate without impermeable surfaces and infiltrate brine to the ground or groundwater need to register with DES under the Groundwater Discharge Permit and Registration Rules, Env-Wq 402. This is a free registration and is a method of tracking potential contaminant sources. If there are sensitive receptors nearby, some sites may be required to monitor drinking water wells and/or the groundwater. The registration form can be found at: [http://des.nh.gov/organization/divisions/water/dwgb/dwspp/bmps/documents/floor\\_drain\\_form.pdf](http://des.nh.gov/organization/divisions/water/dwgb/dwspp/bmps/documents/floor_drain_form.pdf)

Best management practices (BMPs) for locating a new deicing materials storage facility should include the following:

- The facility should be located in an area that is not environmentally sensitive. Avoid areas where there are wells, reservoirs, or within the footprint of stratified-drift aquifers.
- The facility should be located on a flat site away from surface water and wetlands.
- Site drainage should be designed to direct clean stormwater away from the operations and storage areas in order to keep the stockpiles as dry as possible.

Appendix: I NHDES Storage and Management of Salt Deicing Materials Fact Sheet

- Drainage that is contaminated with salt should be directed to a sewage treatment plant (subject to municipal approval), collected for use in pre-wetting activities or sent for proper disposal.

### Structures and Work Areas

Ideally deicing material storage facilities should be completely enclosed, with storage and working areas on impervious surfaces such as asphalt or coated concrete. There should be stormwater drainage controls to prevent runoff water and snow melt from contacting or running through loading and material storage areas. Overhead cover to protect material from exposure to snow and rain should be installed to minimize runoff and inventory loss. A fixed roof is preferred over a tarp, because it is very difficult to keep storage piles completely covered with tarps during winter months and storm events.

Buildings should have concrete foundations and can be designed using dome, barn, or fabric style structures. For more information on constructing salt storage units, calculating how much space is needed for storage, and salting practices, see the Salt Institute's publications at <http://www.saltinstitute.org/>. *The Salt Storage Handbook* contains tables that indicate how much space is required to cover different height piles, and provides surface areas of exposed salt piles, to help in calculating number and size of tarps for temporarily covering salt piles.

The following BMPs should be considered when storing and managing deicing materials.

#### Storage Structures

- All salt and sand/salt mixtures should be stored on pads of impermeable asphalt or concrete. Storage and loading areas should have an impermeable floor constructed of asphalt, concrete or other suitable material that extends around the buildings and work area exterior. The area should be sloped away to prevent stormwater from entering the loading areas or structure.
- Concrete pads and walls should be treated to prevent concrete deterioration (spalling).
- Structure hardware should be galvanized and concrete block buildings should be waterproofed inside.
- If using a three-sided building, the exposed salt at the open end should be covered.
- Stormwater and snowmelt runoff should be properly controlled. Building floors and storage pads should be sloped to prevent ponding and allow any water to drain away from the storage piles.

#### On-Site Management: Delivery/Handling/Loading

- All sand and sand/salt mixtures temporarily out in the open should be covered to prevent salt from being washed or blown from the pile.
- If a permanent under-roof work area is not possible, then storage and handling activities should be conducted on impermeable (bituminous) pads. Any deicing materials left outdoors should be completely covered with waterproof tarpaulins.
- All surplus materials must be removed from the site when winter activity is finished.
- Working areas should be bermed and sloped to allow snow melt and stormwater to drain away from the area. In some cases, it may be necessary to channel water to a collection point, such as a sump, holding tank, or lined basin for collection.
- Storage and distribution should only be conducted during the fall/winter season.

- Spreaders should not be overloaded such that material spills off the vehicle. A plan for loading operations to prevent overfilling vehicles and eliminating material spillage during transportation should be developed and implemented.
- Salt spilled at the storage yard and loading areas should be collected and returned to the storage pile.
- Annual inspection and repairs should be carried out prior to the start of each season. Ongoing inspection of storage structures, work areas, and deicing liquid storage tanks should be carried out during the season.
- Solid bagged materials should be stored securely, indoors if possible.
- Spreaders should only be washed at a location where the wash water is properly managed. (See DES fact sheet WD-DWGB-22-10 Management of Vehicle Wash Water.)
- Liquid storage tanks should be designed such that a plumbing failure will not result in release of the contents. Backflow prevention may be necessary on some plumbing applications.
- Liquid storage tanks should be protected from impact from vehicles moving about the yard and be located such that spilled material can be contained and retrieved in the event of a tank or piping failure. Secondary containment should be provided around large liquid storage tanks.

### **Brine Storage and Management**

In recent years brine has been used on roads prior to storms as an effective ice preventative, reducing the amount of deicing materials needed during a storm event. The water that runs off storage and loading areas can be collected into watertight tanks or lined basin(s) and re-used in pre-storm wetting of roads. Any brine storage should be designed with inert materials that are compatible with salt.

Brine stored using holding tanks must be managed so that there are no releases to drains, groundwater or surface waters. If there is a floor drain in a building where brine is stored, it must be connected to a municipal sewer system (with the approval of the local authority), routed to a registered holding tank or permanently sealed. (see fact sheet WD-DWGB-22-8 Holding Tanks for Floor Drains)

Storage ponds or collection basins used for brine storage must be lined and must not receive runoff from areas other than the storage and operations areas. The basin itself must be impermeable to prevent infiltration of the collected water into the ground. The basin may need a roof or cover to reduce the accumulation of snow and rain water. The collection of this runoff water would only be necessary during the winter maintenance months (November through March). During the remaining seven months of the year, the non-brine stormwater can be redirected from the brine storage to a natural discharge point.

The preferred management option for any brine collected is for use as a pre-wetting agent for roads prior to winter storms. The release of this collected water to the ground, groundwater, or a stormwater system during operation or at season's end is not permissible and as a consequence, this type of runoff management may require disposal of the brine by one of the following methods: (1) discharge directly to a publicly owned treatment works (POTW) with local approval; (2) pumping and transporting the salt water to a POTW system by tank truck; (3) evaporation; or (4) treatment to remove salt and on-site discharge under a Nondomestic Wastewater Registration.

**For Additional Information**

For more information, please contact the Drinking Water and Groundwater Bureau at (603) 271-2513 or [dwgbinfo@des.nh.gov](mailto:dwgbinfo@des.nh.gov), or visit our website at <http://des.nh.gov/organization/divisions/water/dwgb/index.htm>. All of the bureau's fact sheets are online at <http://des.nh.gov/organization/commissioner/pip/factsheets/dwgb/index.htm>.

**References:**

- Salt Institute ([www.saltinstitute.org](http://www.saltinstitute.org))
- Michigan Department of Environmental Quality ([www.michigan.gov/deq/](http://www.michigan.gov/deq/))
  - Salt and Brine Storage Guidance
  - Guide to Salt Storage Requirements for Small Commercial Snow Removal Services
- Environment Canada (<http://www.ec.gc.ca/nopp/roadsalt/en/index.cfm>)
  - Best Management Practices for Salt Use on Private Roads, Parking Lots & Sidewalks
- SIMA (Snow & Ice Management Assoc.) [www.sima.org](http://www.sima.org)

Note: This fact sheet is accurate as of June 2010. Statutory or regulatory changes or the availability of additional information after this date may render this information inaccurate or incomplete.

BLACK ICE

Surface Temp. Range (° F)	Surface Condition	Initial Maintenance Action	Dry Rock Salt Lbs./lm.	Pre-Wetted Rock Salt Lbs./lm	Follow Up Action	Follow Up Rock Salt Lbs./lm	Follow Up Pre- Wetted Rock Salt Lbs./lm	Comments
Above 32	Dry or Damp	Apply pre-wetted rock salt or direct liquids to prevent formation.		115	None, see comments.			Monitor pavement temperature closely; begin treatment if pavement temperature starts to fall toward 32 and it is at or below the dew point.
23 to 32	Frost or Black Ice	Apply pre-wetted rock salt or direct liquid; use dry salt if pre-wetted not available.	275	225	Re-apply pre-wetted rock salt as needed.	115	90	1) Monitor pavement temperatures closely; if pavement becomes wet or if thin ice forms re-apply chemicals. 2) Do not apply direct liquids on ice so thick that the pavement cannot be seen. 3) Heavier follow up application(s) may be necessary.
15 to 23	Frost or Black Ice	Apply pre-wetted rock salt; use dry rock salt if pre-wetted not available.	360	275	Re-apply pre-wetted or dry rock salt as needed	115	90	1) Monitor pavement temperature closely; if pavement becomes wet or if thin ice forms re-apply chemicals. 2) Do not apply direct liquids on ice so thick that the pavement can not be seen. 3) Heavier follow up applications(s) may be necessary.
Below 15	Frost or Black Ice	Apply abrasives			Apply abrasives			1) Refer to Snow and Ice Guidelines Section 5.4406, paragraph B. for abrasive application rates.

Notes: 1) Black ice or frost is normally a spot condition – these application rates would be applied to areas susceptible to the formation of black ice or areas where black ice has developed. Watch for freezing surface temperatures below dew point with sources of vapor, clear night skies and light winds. 2) Refer to direct liquid chemical application guide lines (Appendix C Page C – 10) if anti-icing liquids are used.

Appendix J Winter Maintenance Charts (NYSDOT, 2007)

SLEET

Surface Temp. Range (° F)	Surface Condition	Initial Maintenance Action	Dry Rock Salt Lbs./lm.	Pre-Wetted Rock Salt Lbs./lm	Follow Up Action	Follow Up Rock Salt Lbs./lm	Follow Up Pre- Wetted Rock Salt Lbs./lm	Comments
Above 32	Dry	Patrol and spot treat as needed. See comments.			Patrol and spot treat as needed. See comments.			1) Monitor pavement temperatures closely and anticipate drops toward 32 F and below. 2) Treat icy patches with pre-wetted rock salt at 115 lbs./lm.
Above 32	Snow, slush, or wet.	Apply pre-wetted or dry rock salt, plow if plowable.	115	90	Re-apply pre-wetted or dry rock salt as needed.	115	90	1) Monitor pavement temperatures closely and anticipate drops toward 32F. 2) Treat icy patches and colder areas with higher applications. 3) Increase rates if precipitation intensity increases.
Above 32, but dropping to 32 or below soon.	Snow, slush, or wet.	Apply pre-wetted or dry rock salt, plow if plowable.	180	115	Re-apply pre-wetted or dry rock salt as needed.	180	115	1) Monitor pavement temperatures and precipitation closely. 2) Treat icy patches and colder areas with higher application rates. 3) Increase application rates if precipitation intensity increases.
23 to 32	Snow, slush, or wet.	Apply pre-wetted or dry rock salt, plow if plowable.	225	180	Re-apply pre-wetted or dry rock salt as needed.	225	180	1) Monitor pavement temperatures and precipitation closely. 2) Treat icy patches and colder areas with higher application rates. 3) Increase application rates if precipitation intensity increases.
15 to 23	Snow, slush, or wet.	Apply pre-wetted or dry rock salt, plow if plowable.	275	225	Re-apply pre-wetted or dry rock salt as needed.	275	225	1) Monitor pavement temperatures and precipitation closely. 2) Treat icy patches and colder areas with higher application rates. 3) Increase application rates if precipitation intensity increases.
Below 15	Any condition.	Apply abrasives.			Re-apply abrasives.			1) Refer to Snow and Ice Guidelines Section 5.4406 (B) for abrasive application rates.

Notes: 1) Sleet that creates accumulating ice will require more aggressive treatment.

Appendix J Winter Maintenance Charts (NYSDOT, 2007)

LIGHT SNOW

Surface Temp. Range (° F)	Surface Condition	Initial Maintenance Action	Dry Rock Salt Lbs./lm.	Pre-Wetted Rock Salt Lbs./lm	Follow Up Action	Follow Up Rock Salt Lbs./lm	Follow Up Pre- Wetted Rock Salt Lbs./lm	Comments
Above 32	Wet, slush or light snow covered.	Patrol and spot treat as needed. See comments.			Patrol and spot treat as needed. See comments.			1) Monitor pavement temperature for drops toward 32 F. 2) Blast isolated icy patches with salt, treat slushy areas beginning to freeze with 225 dry/180 pre-wet, lbs./lm and plow as needed
Above 32, but dropping to 32 or below soon.	Dry	Apply pre-wetted rock salt or direct liquids. Patrol and spot treat as needed. See comments.		180	Patrol and spot treat as needed. See comments.			1) Monitor pavement temperature and precipitation and use select appropriate follow up as conditions change. 2) Refer to Snow and Ice Guidelines for appropriate direct application of liquid anti-icing chemicals.
Above 32, but dropping to 32 or below soon.	Wet, slush, or light snow covered.	Apply pre-wetted or dry rock salt, plow as needed.	225	180	Plow and re-apply pre-wetted or dry rock salt as needed.	115	90	1) Application will need to be more frequent at lower temperature and higher snowfall rates. 2) Adjust application rates as surface conditions and precipitation intensities change.
23 to 32	Dry	Apply pre-wetted rock salt or direct liquids.		180	See comments.			1) Monitor pavement temperature and precipitation and use select appropriate follow up as conditions change. 2) Refer to Snow and Ice Guidelines for appropriate direct application of liquid anti-icing chemicals.
23 to 32	Wet, slush or light snow covered.	Apply pre-wetted or dry rock salt, plow as needed.	225	180	Plow and re-apply pre-wetted or dry rock salt as needed.	115	90	1) Application will need to be more frequent at lower temperature and higher snowfall rates. 2) Adjust application rates as surface conditions and precipitation intensities change.
15 to 23	Wet, slush or light snow covered.	Apply pre-wetted rock salt, plow as needed.	275	225	Plow and re-apply pre-wetted rock salt as needed.	180	115	1) If sufficient moisture is present, dry rock salt can be applied. Dry pavement at these temperatures is better left untreated if snow does not track to surface.
Below 15	Dry or light snow covered.	Plow as needed.			Plow as needed.			1) Abrasives can be applied to enhance traction, a heavy salt mix will create glazing. Refer to Snow & Ice Guidelines Section 5.4406 (B) for abrasive application rates. Apply rock salt in anticipation of rising temperatures.

Notes: 1) Rush Period Traffic on high volume highways may require more aggressive initial treatments. 2) Use weather information to anticipate changes in storm intensity, surface temperatures and adapt the storm treatment accordingly. Use guidelines for moderate/heavy snow during periods of heavier intensity. . 3) Refer to direct liquid chemical application guides lines (Appendix C, Page C – 10) if anti-icing liquids are used.

Appendix J Winter Maintenance Charts (NYSDOT, 2007)



MODERATE OR HEAVY SNOW

Surface Temp. Range (° F)	Surface Condition	Initial Maintenance Action	Dry Rock Salt Lbs./lm.	Pre-Wetted Rock Salt Lbs./lm	Follow Up Action	Follow Up Rock Salt Lbs./lm	Follow Up Pre- Wetted Rock Salt Lbs./lm	Comments
Above 32	Wet, slush or light snow covered.	Patrol and spot treat as needed. See comments.			Patrol and spot treat as needed. See comments.			1) Monitor pavement temperature for drops toward 32 F. 2) Blast isolated icy patches with salt, treat slushy areas beginning to freeze with 225 dry/180 pre-wet, lbs./lm and plow as needed.
Above 32, but dropping to 32 or below soon.	Dry	Apply pre-wetted rock salt or direct liquids. Patrol and spot treat as needed. See comments.		180	Patrol and spot treat as needed. See comments.			1) Monitor pavement temperature and precipitation and use select appropriate follow up as conditions change. 2) Refer to Snow and Ice Guidelines for appropriate direct application of liquid anti-icing chemicals.
Above 32, but dropping to 32 or below soon.	Wet, slush, or light snow covered.	Apply pre-wetted or dry rock salt, plow as needed.	225	180	Plow and re-apply pre-wetted or dry rock salt as needed.  Slushy Conditions	225  115	180  90	1) If normal cycle times can not be maintained, the application rates can be increased to 275dry/225 pre-wet, lbs./lm to accommodate longer cycles. 2) Rates may be reduced during periods of light snow but use full applications in anticipation of heavy intensities/falling surface temperatures.
23 to 32	Dry	Apply pre-wetted rock salt or direct liquids.		180	See comments.			1) Monitor pavement temperature and precipitation and use select appropriate follow up as conditions change. 2) Refer to Snow and Ice Guidelines for appropriate direct application of liquid anti-icing chemicals.
23 to 32	Wet, slush or light snow covered.	Apply pre-wetted or dry rock salt, plow as needed.	225	180	Plow and re-apply pre-wetted or dry rock salt as needed.  Slushy Conditions	225  115	180  90	1) If normal cycle times can not be maintained, the application rates can be increased to 275dry/225 pre-wet, lbs./lm to accommodate longer cycles. 2) Rates may be reduced during periods of light snow but use full applications in anticipation of heavy intensities/falling surface temperatures.
15 to 23	Wet, slush or light snow covered.	Apply pre-wetted rock salt, plow as needed.	275	225	Plow and re-apply pre-wetted rock salt as needed.  Slushy Conditions	275  225	225  115	1) If normal cycle times can not be maintained, the application rates can be increased to 360dry/275 pre-wet, lbs./lm to accommodate longer cycles. 2) Rates may be reduced during periods of light snow but use full applications in anticipation of heavy intensities.
Below 15	Dry or light snow covered.	Plow as needed.			Plow as needed.			1) Abrasives can be applied to enhance traction, a heavy salt mix will create glazing. Refer to Snow & Ice Guidelines Section 5.4406 (B) for abrasive application rates. Apply rock salt in anticipation of rising temperatures.

Notes: 1) Rush Period Traffic on high volume highways may require more aggressive initial treatments. 2) Increased cycle times will require heavier application rates. Anticipate changes in storm intensity and surface temperatures and use appropriate chart selection. 3) Refer to direct liquid chemical application guides lines (Appendix C, Page C –10) if anti-icing liquids are used.

Appendix J Winter Maintenance Charts (NYSDOT, 2007)

GLOSSARY OF TERMS

**Black Ice.** Popular term for a very thin coating of clear, bubble free, homogenous ice which forms on a pavement with temperature at or slightly above 32° F when the temperature of the air in contact with the ground is below the freeze-point of water and small super cooled water droplets deposit on the surface and coalesce (flow together) before freezing. This often occurs when pavement temperature is 32° F or below and is at or below Dew Point.

**Chemical Spread Rate.** Also known as chemical application rate. For solid applications it is simply the weight of the chemical applied per lane mile. For liquid applications it is in gallons per lane mile when applied straight and gallons per ton when used to pre-wet solid chemicals.

**Freezing Rain.** Super cooled droplets of liquid precipitation falling on a surface whose temperature is below or slightly above freezing, resulting in a hard, slick, generally thick coating of ice commonly called a glaze or clear ice. Non-super cooled raindrops falling on a surface whose temperature is well below freezing will also result in a glaze.

**Frost.** Also called hoarfrost. Ice crystals in the form of scales, needles, feathers or fans deposited on the surfaces cooled by radiation or other process. The deposits may be composed of drops of dew frozen after deposition and of ice formed directly from water vapor at a temperature below 32° F (sublimation). Most often occurs when pavement temperature is 32° F or below and is at or below Dew Point.

**Light Snow.** Snow falling at the rate of less than ½ inch per hour; visibility is not affected adversely.

**Liquid Chemical.** A chemical solution; with a specified percentage of chemical that is applied at the rate of gallons per lane when applied straight and gallons per ton when used to pre-wet solid chemicals.

**Moderate or Heavy Snow.** Snow falling a rate of ½ inch per hour or greater; visibility may be reduced.

**Sleet.** A mixture of rain and snow which has been partially melted by falling through the atmosphere with a temperature slightly above freezing.

**Slush.** Accumulation of snow which lies on an impervious base and is saturated with water in excess of the freely drained capacity. It will not support any weight when stepped or driven on but will “squish” until the base support is reached.

April, 2006

Appendix J Winter Maintenance Charts (NYSDOT, 2007)

### Appendix K : Application Rate Guidelines for Parking Lots:

	Surface Temp. Range (°F)	Surface Condition	Initial Maintenance Action	Dry Rock Salt (lb./1000 sq.ft.)	Pre-wetted Rock Salt (lb./1000 sq.ft.)	Follow Up Action	Follow Up Rock Salt (lb./1000 sq.ft.)	Follow Up Pre-wetted Rock Salt (lb./1000 sq.ft.)	Comments
Black Ice	Above 32	Dry or damp	Apply pre-wetted rock salt or direct liquids to prevent formation		1.82	None, see comments			Monitor pavement temperature closely; begin treatment if pavement temperature starts to fall toward 32° and is at or below the dew point
	23 to 32	Frost or black ice	Apply pre-wetted rock salt or direct liquids; use dry salt if pre-wetted unavailable	4.34	3.55	Re-apply pre-wetted rock salt as needed	1.82	1.42	1) Monitor pavement temperature closely; if pavement becomes wet or if thin ice forms, reapply chemicals. 2) Do not apply direct liquids on ice so thick that the pavement cannot be seen. 3) Heavier follow up applications may be necessary.
	15 to 23	Frost or black ice	Apply pre-wetted rock salt; use dry rock salt if pre-wetted unavailable	5.68	4.34	Re-apply pre-wetted rock salt as needed	1.82	1.42	1) Monitor pavement temperature closely; if pavement becomes wet or if thin ice forms, reapply chemicals. 2) Do not apply direct liquids on ice so thick that the pavement cannot be seen. 3) Heavier follow up applications may be necessary.
	< 15	Frost or black ice	Apply abrasives			Apply abrasives			1) Refer to Snow and Ice Guidelines Section 5.4406 (B) for abrasives application rates

1) Black ice or frost is normally a spot condition - these application rates would be applied to areas susceptible to the formation of black ice areas where black ice has developed. Watch for freezing surface temperatures below dew point with sources of v

Appendix K UNH T2 Application Rates for Parking Lots (derived from data obtained from NYSDOT, 2007)

	Surface Temp. Range (°F)	Surface Condition	Initial Maintenance Action	Dry Rock Salt (lb./1000 sq. ft.)	Pre-wetted Rock Salt (lb./1000 sq. ft.)	Follow Up Action	Follow Up Rock Salt (lb./1000 sq. ft.)	Follow Up Pre-wetted Rock Salt (lb./1000 sq.ft.)	Comments
Freezing Rain	Above 32	Wet or slushy	Apply pre-wetted or dry rock salt, plow if possible	1.82	1.42	Monitor precipitation and temperature.			1) Monitor pavement closely and anticipate drop toward 32° F and below. 2) Adjust application rates as surface conditions and precipitation intensities change.
	Above 32, dropping below soon	Wet or slushy	Apply pre-wetted or dry rock salt, plow if possible	2.84	1.82	Re-apply pre-wetted or dry rock salt as needed	2.84	1.82	1) Monitor pavement temperatures and precipitation closely. 2) Treat icy patches and colder areas with higher applications. 3) Increase applications if precipitation intensity increases or surface shows signs of icing.
	23 to 32	Wet or slushy	Apply pre-wetted or dry rock salt, plow if possible	4.34	3.55	Re-apply pre-wetted or dry rock salt as needed	4.34	3.55	1) Monitor pavement temperatures and precipitation closely and adjust application rates as surface conditions and precipitation intensities change. 2) Treat icy patches and colder areas with higher applications. 3) Increase applications if precipitation i
	23 to 32	Icy	Apply pre-wetted or dry rock salt	5.68	5.05	Re-apply pre-wetted or dry rock salt as needed	5.68	5.05	1) Use application rate for "wet and slushy" when icing condition is removed. 2) increase application rate if precipitation intensity increases or if pavement shows signs or refreezing
	15 to 23	Wet or slushy	Apply pre-wetted or dry rock salt, plow if possible	5.68	4.34	Re-apply pre-wetted or dry rock salt as needed	5.68	4.34	1) Monitor pavement temperatures and precipitation closely and adjust application rates as surface conditions and precipitation intensities change. 2) Treat icy patches and colder areas with higher applications. 3) Increase applications if precipitation i
	15 to 23	Icy	Apply pre-wetted or dry rock salt	7.10	5.68	Re-apply pre-wetted or dry rock salt as needed	7.10	5.68	1) Use application rate for "wet and slushy" when icing condition is removed. 2) increase application rate if precipitation intensity increases or if pavement shows signs or refreezing
	Below 15	Dry, wet, or icy	Apply abrasives			Re-apply abrasives			1) Refer to Snow and Ice Guidelines Section 5.4406 (B) for abrasives application rates

1) Freezing rain requires a timely and aggressive response to prevent ice formation; application rates should be increased if not effective or cycle times are increased due to difficult driving.

## Appendix K UNH T2 Application Rates for Parking Lots (derived from data obtained from NYSDOT, 2007)

	Surface Temp. Range (°F)	Surface Condition	Initial Maintenance Action	Dry Rock Salt (lb./1000 sq. ft.)	Pre-wetted Rock Salt (lb./1000 sq. ft.)	Follow Up Action	Follow Up Rock Salt (lb./1000 sq. ft.)	Follow Up Pre-wetted Rock Salt (lb./1000 sq.ft.)	Comments
Sleet	>32	Dry	Patrol and spot treat as needed. See comments.			Patrol and spot treat as needed. See comments			1) Monitor pavement closely and anticipate drop toward 32° F and below. 2) Treat icy patches with pre-wetted rock salt at 3.64 lb./1000sq.ft.
	>32	Snow, slush, or wet	Apply pre-wetted or dry rock salt, plow if plowable	1.82	1.42	Re-apply pre-wetted or dry rock salt as needed	1.82	1.42	1) Monitor pavement temperatures closely and anticipate drops toward 32°F. 2) Treat icy patches and colder areas with higher applications. 3) Increase rates if precipitation intensity increases.
	Above 32, dropping below soon	Snow, slush, or wet	Apply pre-wetted or dry rock salt, plow if plowable	2.84	1.82	Re-apply pre-wetted or dry rock salt as needed	2.84	1.82	1) Monitor pavement temperatures and precipitation closely. 2) Treat icy patches and colder areas with higher applications. 3) Increase applications if precipitation intensity increases.
	23 to 32	Snow, slush, or wet	Apply pre-wetted or dry rock salt, plow if plowable	3.55	2.84	Re-apply pre-wetted or dry rock salt as needed	3.55	2.84	1) Monitor pavement temperatures and precipitation closely. 2) Treat icy patches and colder areas with higher applications. 3) Increase applications if precipitation intensity increases.
	15 to 23	Snow, slush, or wet	Apply pre-wetted or dry rock salt, plow if plowable	4.34	3.55	Re-apply pre-wetted or dry rock salt as needed	4.34	3.55	1) Monitor pavement temperatures and precipitation closely. 2) Treat icy patches and colder areas with higher applications. 3) Increase applications if precipitation intensity increases.
	Below 15	Any condition	Apply abrasives			Re-apply abrasives			1) Refer to Snow and Ice Guidelines Section 5.4406 (B) for abrasives application rates

1) Sleet that creates accumulating ice will require more aggressive treatment

### Appendix K UNH T2 Application Rates for Parking Lots (derived from data obtained from NYSDOT, 2007)

	Surface Temp. Range (°F)	Surface Condition	Initial Maintenance Action	Dry Rock Salt (lb./1000 sq. ft.)	Pre-wetted Rock Salt (lb./1000 sq. ft.)	Follow Up Action	Follow Up Rock Salt (lb./1000 sq. ft.)	Follow Up Pre-wetted Rock Salt (lb./1000 sq. ft.)	Comments
Light Snow	Above 32	Wet, slush, or light snow covered.	Patrol and spot treat as needed. See comments.			Patrol and spot treat as needed. See comments			1) Monitor pavement temperature for drops toward 32°F. 2) Blast isolated icy patches with salt, treat slushy areas beginning to freeze with 7.1 dry/5.68 pre-wet, lb./1000 sq.ft. and plow as needed.
	Above 32, dropping below soon	Dry	Apply pre-wetted rock salt or direct liquids. Patrol and spot treat as needed. See comments.		2.84	Patrol and spot treat as needed. See comments			1) Monitor pavement temperature and precipitation and use select appropriate follow up as conditions change. 2) Refer to direct liquid guidelines for appropriate application of liquid anti-icing chemicals.
	Above 32, dropping below soon	Wet, slush, or light snow covered.	Apply pre-wetted or dry rock salt, plow as needed	3.55	2.84	Plow and re-apply pre-wetted or dry rock salt as needed	1.82	1.42	1) Application will need to be more frequent at lower temperatures and higher snowfall rates. 2) Adjust application rates as surface conditions and precipitation intensities change.
	23 to 32	Dry	Apply pre-wetted rock salt or direct liquids.		2.84	See comments.			1) Monitor pavement temperature and precipitation and use select appropriate follow up as conditions change. 2) Refer to Section 5 (Step 3) for appropriate direct application of liquid anti-icing chemicals.
	23 to 32	Wet, slush, or light snow covered.	Apply pre-wetted or dry rock salt, plow as needed	3.55	2.84	Plow and re-apply pre-wetted or dry rock salt as needed	1.82	1.42	1) Application will need to be more frequent at lower temperatures and higher snowfall rates. 2) Adjust application rates as surface conditions and precipitation intensities change.
	15 to 23	Wet, slush, or light snow covered.	Apply pre-wetted or dry rock salt, plow as needed	4.34	3.55	Plow and re-apply pre-wetted rock salt as needed	2.84	1.82	1) If sufficient moisture is present, dry rock salt can be applied. Dry pavement at these temperatures is better left untreated if snow does not track to surface.
	Below 15	Dry or light snow covered.	Plow as needed.			Plow as needed.			1) Abrasives can be applied to enhance traction, a heavy salt mix will create glazing. Apply rock salt in anticipation of rising temperatures.

1) Rush period traffic on high volume highways may require more aggressive initial treatments. 2) Use weather information to anticipate changes in storm intensity, surface temperatures and adapt the storm treatment accordingly. Use guidelines for moderate

## Appendix K UNH T2 Application Rates for Parking Lots (derived from data obtained from NYSDOT, 2007)

	Surface Temp. Range (°F)	Surface Condition	Initial Maintenance Action	Dry Rock Salt (lb./1000 sq. ft.)	Pre-wetted Rock Salt (lb./1000 sq. ft.)	Follow Up Action	Follow Up Rock Salt (lb./1000 sq. ft.)	Follow Up Pre-wetted Rock Salt (lb./1000 sq.ft.)	Comments
Moderate to Heavy Snow	Above 32	Wet, slush, or light snow covered.	Patrol and spot treat as needed. See comments.			Patrol and spot treat as needed. See comments			1) Monitor pavement temperature for drops toward 32°F. 2) Blast isolated icy patches with salt, treat slushy areas beginning to freeze with 7.1 dry/5.68 pre-wet, lb./1000 sq.ft. and plow as needed.
	Above 32, dropping below soon	Dry	Apply pre-wetted rock salt or direct liquids. Patrol and spot treat as needed. See comments.		2.84	Patrol and spot treat as needed. See comments			1) Monitor pavement temperature and precipitation and use select appropriate follow up as conditions change. 2) Refer to direct liquid guidelines for appropriate application of liquid anti-icing chemicals.
	Above 32, dropping below soon	Wet, slush, or light snow covered.	Apply pre-wetted or dry rock salt, plow as needed	3.55	2.84	Plow and re-apply pre-wetted or dry rock salt as needed (Slushy conditions)	3.55(1.82)	2.84(1.42)	1) Application rates can be increased to 8.68 dry/7.1 pre-wet, if normal cycle times cannot be maintained. 2) Rates may be reduced during periods of light snow but use full applications in anticipation of heavy intensities/falling surface temperatures.
	23 to 32	Dry	Apply pre-wetted rock salt or direct liquids.		2.84	See comments.			1) Monitor pavement temperature and precipitation and use select appropriate follow up as conditions change. 2) Refer to direct liquid guidelines for appropriate application of liquid anti-icing chemicals.
	23 to 32	Wet, slush, or light snow covered.	Apply pre-wetted or dry rock salt, plow as needed	3.55	2.84	Plow and re-apply pre-wetted or dry rock salt as needed (Slushy conditions)	3.55(1.82)	2.84(1.42)	1) Application rates can be increased to 8.68 dry/7.1 pre-wet, if normal cycle times cannot be maintained. 2) Rates may be reduced during periods of light snow but use full applications in anticipation of heavy intensities/falling surface temperatures.
	15 to 23	Wet, slush, or light snow covered.	Apply pre-wetted rock salt, plow as needed.	4.34	3.55	Plow and re-apply pre-wetted or dry rock salt as needed (Slushy conditions)	4.34(3.55)	3.55(1.82)	1) Application rates can be increased to 11.36 dry/8.68 pre-wet, if normal cycle times cannot be maintained. 2) Rates may be reduced during periods of light snow but use full applications in anticipation of heavy intensities/falling surface temperatures.
	Below 15	Dry or light snow covered.	Plow as needed.			Plow as needed			1) Abrasives can be applied to enhance traction, a heavy salt mix will create glazing. 2)1) Refer to Snow and Ice Guidelines Section 5.4406 (B) for abrasives application rates3.)Apply rock salt in anticipation of rising temperatures.

1) Rush period traffic on high volume highways may require more aggressive initial treatments. 2) Increased cycle times will require heavier application rates. Anticipate changes in storm intensity and surface temperatures and use appropriate chart select

### Appendix K UNH T2 Application Rates for Parking Lots (derived from data obtained from NYSDOT, 2007

---

# ENVIRONMENTAL Fact Sheet

---



29 Hazen Drive, Concord, New Hampshire 03301 • (603) 271-3503 • [www.des.nh.gov](http://www.des.nh.gov)

---

WD-DWGB-22-10

2010

## Wastewater Discharges from Vehicle Washing

Water used in washing cars, trucks, and other vehicles may contain a wide range of contaminants –especially oil, other hydrocarbons, metals, detergents, road salt and grit. Discharged into surface waters, these contaminants can degrade water quality and harm aquatic life. Discharged into groundwater, they can make it unfit for drinking. To avoid these problems, and the legal consequences that may result, the following guidelines apply to facilities where vehicles are washed on a regular basis and the wash water is collected by a conveyance such as a drain, catch basin, ditch or swale.\* Owners of a car wash or a commercial establishment that offers vehicle washing have four options for their wastewater discharges:

1. Operate a closed system with wastewater recycling (no discharge of wastewater).
2. Discharge to a municipal sanitary sewer.
3. Obtain a groundwater discharge permit.
4. Wash fewer than 30 vehicles per week and discharge to the ground *surface only*.

### 1. Closed System with No Discharge

This does not require a permit; however, it may require a “Holding Tank Registration” if the treatment system has a grit and oil tank that is pumped out. The water and sludge that are pumped from the tank must be collected and disposed of at an approved disposal facility, i.e., a wastewater treatment plant or hazardous waste disposal facility, depending on the nature of the material.

### 2. Discharge to Municipal Sanitary Sewer

Connections to your municipal sanitary sewer are controlled by the local sewer authority. Contact the local authority regarding restrictions. Some local sewer authorities do not allow connection of floor drains, while others allow connection only with adequate pretreatment, e.g., an oil/grit separator, or other controls. If you connect an existing floor drain to a municipal sanitary sewer, you still need to notify DES.

### 3. Obtain a Groundwater Discharge Permit

You may discharge vehicle wash water directly to the ground if both of the following are true:

- a. A groundwater discharge permit is obtained in accordance with Env-Wq 402.11; and
- b. The wash water is treated to ambient groundwater quality standards ([Env-Or 600](#), Table 600-1) using best available technology (typically granular activated carbon).

---

\* These restrictions do not apply to occasional vehicle washing, such as at residences or occasional events such as fund-raising car washes. For more information on community car washes and water quality see fact sheet WD-WMB-14 “Community Car Washes and Water Quality” at <http://des.nh.gov/organization/commissioner/pip/factsheets/wmb/documents/wmb-14.pdf>.



#### 4. Wash Fewer than 30 Vehicles per Week

If you wash fewer than 30 vehicles per week, you may be able to discharge indirectly to groundwater without obtaining a groundwater discharge permit. However, you need to follow Env-Wq 401 Best Management Practices for Groundwater Protection to avoid contamination of your wash water with regulated substances. You also need to register your discharge and floor drain, if any. To avoid having to obtain a groundwater discharge permit, you must meet *all* of the following conditions:

- a. Best Management Practices for Groundwater Protection are followed.
- b. The floor drain is *not* in an area where regulated contaminants are used or stored.
- c. The wastewater:
  - Is *not* from power washing, steam cleaning, engine cleaning or undercarriage cleaning.
  - Does *not* contain soaps or other products that contain regulated contaminants.
  - Does *not* result in a surface water discharge.
  - Discharges to the ground surface.
  - Contains only approved detergents.
  - Leads to an oil-water separator or other pretreatment method prior to infiltration.
  - Is registered with DES in accordance with [Env-Wq 402.33](#).

Owners of facilities with these discharges are responsible for ensuring that regulated contaminants are not discharged and that groundwater is suitable for drinking without treatment.

#### Surface Water Discharges

In order to adequately protect the quality of surface water in New Hampshire, direct discharges of wastewater derived from car washing into surface water is prohibited. For more information about permitting of discharges to surface water, contact the DES Wastewater Engineering Bureau at (603) 271-3908.

#### For Additional Information

For more information about groundwater discharges, holding tank registration, floor drain registrations, and rules, please visit the DES Drinking Water Source Protection webpage at <http://des.nh.gov/organization/divisions/water/dwgb/dwsp/index.htm>, or call (603) 271-2858.

For additional information, please contact the Drinking Water and Groundwater Bureau at (603) 271-2513 or [dwgbinfo@des.nh.gov](mailto:dwgbinfo@des.nh.gov), or visit <http://des.nh.gov/organization/divisions/water/dwgb/index.htm>. All of the bureau's fact sheets are on-line at <http://des.nh.gov/organization/commissioner/pip/factsheets/dwgb/index.htm>.

**Table 1. Weather event: frost or black ice**

<u>PAVEMENT TEMPERATURE RANGE AND TREND, AND RELATION TO DEW POINT</u>	<u>INITIAL OPERATION</u>			<u>SUBSEQUENT OPERATIONS</u>		<u>COMMENTS</u>
	<b>Pavement surface at time of initial operation</b>	<b>Maintenance action</b>	<b>Brine application rate in Gallons per Lane Mile</b>	<b>Maintenance action</b>	<b>Brine application rate in Gallons per Lane Mile</b>	
<b>Above 32 degrees Fahrenheit.</b> Steady or rising	Frost or black ice or forecast for frost or black ice.	See comments		See comments		1)Monitor pavement temperature closely. Begin treatment if temperatures to fall to 32 degrees Fahrenheit or below the dew point. Apply brine at 25 gallons per lane mile.
<b>28 to 32 degrees Fahrenheit</b> Remaining in that range or falling to 32 degrees Fahrenheit or below, and equal to or below the dew point.		Apply brine	25 gallons per lane mile	Reapply brine when needed.	40 gallons per lane mile	1)Monitor pavement closely. If pavement becomes wet or if thin ice forms, reapply brine at a higher application rate. 2)Do not apply brine on ice so thick that the pavement can not be seen.
<b>20 to 28 degrees Fahrenheit</b> Remaining in that range and equal to or below the dew point.		Apply brine	50 gallons per lane mile	Apply brine	50 gallons per lane mile	1)Monitor pavement closely. If thin ice forms, reapply brine at higher application rates. 2)Applications will need to be more frequent at higher levels of condensation if traffic volumes are not enough to disperse condensation. 3)It is not advisable to apply brine at the indicated application rate when the pavement temperature drops below 20 degrees Fahrenheit.
<b>15 to 20 degrees Fahrenheit</b> Steady or falling		Do not apply liquids	Not applicable	Do not apply liquids	Not applicable	Apply only pretreated solid chemical (salt) in this temperature range.
<b>Below 15 degrees Fahrenheit</b> Steady or falling		Do not apply liquids	Not applicable	Do not apply liquids	Not applicable	It is not recommended that chemicals be applied in this temperature range.

**Appendix M: Hamilton NJ Application Rates for Salt Brine**

**Table 2. Weather event: light snowstorm**

<u>PAVEMENT TEMPERATURE RANGE AND TREND</u>	<u>INITIAL OPERATION</u>			<u>SUBSEQUENT OPERATIONS</u>		<u>COMMENTS</u>
	Pavement surface at time of initial operation	Maintenance action	Brine application rate in Gallons per Lane Mile	Maintenance action	Brine application rate in Gallons per Lane Mile	
Above 32 degrees Fahrenheit. Steady or rising	Dry, wet, slush, or light snow cover	None, see comments		None, see comments		1)Monitor pavement temperature closely for drops toward 32 degrees Fahrenheit and below. 2)Treat icy patches if needed with brine at 40 gallons per lane mile. Plow if needed.
Above 32 degrees Fahrenheit 32 degrees Fahrenheit or below is imminent; <i>ALSO</i> 20 to 32 degrees Fahrenheit Remaining in that range	Dry	Apply brine	40 gallons per lane mile	Plow as needed. Reapply brine when needed.	40 gallons per lane mile	1)Application will need to be more frequent at lower temperatures and higher snowfall rates. 2)It is not advisable to apply brine at the indicated spread rate when the pavement temperature drops below 20 degrees Fahrenheit. 3)Do not apply brine onto heavy snow accumulation or packed snow.
	Wet, slush, or light snow cover	Apply brine	40 gallons per lane mile			
15 to 20 degrees Fahrenheit Remaining in that range	Dry, wet, slush or light snow cover	Do not apply liquids	Not applicable	Do not apply liquids	Not applicable	Apply only pretreated solid chemicals (salt) in this temperature range
Below 15 degrees Fahrenheit Steady or falling	Dry or light snow cover	Plow as needed	Not applicable	Plow as needed	Not applicable	It is not recommended that brine be applied in this temperature range.

**Note:**

**BRINE APPLICATIONS.** (1) Time initial and subsequent brine applications to prevent deteriorating conditions or development of packed and bonded snow. (2) Apply brine ahead of traffic rush periods occurring during storm.

**PLOWING.** If needed, plow before brine applications so that excess snow, slush, or ice is removed and pavement is wet, slushy, or lightly snow covered when treated

**Appendix M: Hamilton NJ Application Rates for Salt Brine**

**Table 3. Weather event: light snowstorm with periods) of moderate or heavy snow**

<u>PAVEMENT TEMPERATURE RANGE AND TREND</u>	<u>INITIAL OPERATION</u>			<u>SUBSEQUENT OPERATIONS</u>			<u>COMMENTS</u>
	Pavement surface at time of initial operation	Maintenance action	Brine application rate in Gallons per Lane Mile	Maintenance action	Brine application rate in Gallons per Lane Mile		
					Light snow	Heavier snow	
Above 32 degrees Fahrenheit. Steady or rising	Dry, wet, slush, or light snow cover	None, see comments		None, see comments			1)Monitor pavement temperature closely for drops toward 32 degrees Fahrenheit and below. 2)Treat icy patches if needed with brine at 40 gallons per lane mile. Plow if needed.
Above 32 degrees Fahrenheit 32 degrees Fahrenheit or below is imminent; <i>ALSO</i> 20 to 32 degrees Fahrenheit Remaining in that range	Dry	Apply brine	40 gallons per lane mile	Plow as needed. Reapply brine when needed.	40 gals/lm	80 gals/lm	1)Application will need to be more frequent at lower temperatures and higher snowfall rates. 2)Do not apply brine onto heavy snow accumulation or packed snow. 3)After heavier snow periods and during light snowfall, reduce brine rate to 40 gallons per lane mile. Continue to plow and apply brine as needed.
	Wet, slush, or light snow cover	Apply brine	40 gallons per lane mile				
15 to 20 degrees Fahrenheit Remaining in that range	Dry, wet, slush or light snow cover	Do not apply liquids	Not applicable	Do not apply liquids			Apply only prewetted solid chemical (salt) in this temperature range
Below 15 degrees Fahrenheit Steady or falling	Dry or light snow cover	Plow as needed	Not applicable	Plow as needed			It is not recommended that brine be applied in this temperature range.

**Note:**

**BRINE APPLICATIONS.** (1) Time initial and subsequent brine applications to prevent deteriorating conditions or development of packed and bonded snow. (2) Anticipate increases in snowfall intensity and apply higher application rates prior to or at the beginning of heavier snowfall periods to prevent development of packed and bonded snow. (3) Apply brine ahead of traffic rush periods occurring during storm.

**PLOWING.** If needed, plow before brine applications so that excess snow, slush, or ice is removed and pavement is wet, slushy, or lightly snow covered when treated

**Appendix M: Hamilton NJ Application Rates for Salt Brine**

**Table 4. Weather event: moderate or heavy snowstorm**

<u>PAVEMENT TEMPERATURE RANGE AND TREND</u>	<u>INITIAL OPERATION</u>			<u>SUBSEQUENT OPERATIONS</u>		<u>COMMENTS</u>
	Pavement surface at time of initial operation	Maintenance action	Brine application rate in Gallons per Lane Mile	Maintenance action	Brine application rate in Gallons per Lane Mile	
<b>Above 32 degrees Fahrenheit.</b> Steady or rising	Dry, wet, slush, or light snow cover	None, see comments		None, see comments		1)Monitor pavement temperature closely for drops toward 32 degrees Fahrenheit and below. 2)Treat icy patches if needed with brine at 40 gallons per lane mile. Plow if needed.
<b>Above 32 degrees Fahrenheit</b> 32 degrees Fahrenheit or below is imminent; <i>ALSO</i> <b>30 to 32 degrees Fahrenheit</b> Remaining in that range	Dry	Apply brine	40 gallons per lane mile	Plow as needed. Reapply brine when needed.	40 gallons per lane mile	1)If the desired plowing/treatment frequency cannot be maintained, the application rate can be increased to 80 gallons per lane mile to accommodate longer operational cycles. 2)Do not apply brine onto heavy snow accumulation or packed snow.
	Wet, slush, or light snow cover	Apply brine	40 gallons per lane mile			
<b>20 to 30 degrees Fahrenheit</b> Remaining in that range	Dry	Apply brine	80 gallons per lane mile	Plow as needed. Reapply brine when needed	80 gallons per lane mile	1)If the desired plowing/treatment frequency cannot be maintained, the application rate can be increased to accommodate longer operational cycles. 2)Do not apply brine onto heavy snow accumulation or packed snow.
	Wet, slush, or light snow cover	Apply brine	80 gallons per lane mile			
<b>15 to 20 degrees Fahrenheit</b> Remaining in that range	Dry, wet, slush or light snow cover	Do not apply liquids	Not applicable	Do not apply liquids	Not applicable	Apply only pretreated solid chemical (salt) in this temperature range.
<b>Below 15 degrees Fahrenheit</b> Steady or falling	Dry or light snow cover	Plow as needed	Not applicable	Plow as needed	Not applicable	It is not recommended that brine be applied in this temperature range.

**Note:**

**BRINE APPLICATIONS.** (1) Time initial and subsequent brine applications to prevent deteriorating conditions or development of packed and bonded snow. (2) Apply brine ahead of traffic rush periods occurring during storm.

**PLOWING.** If needed, plow before brine applications so that excess snow, slush, or ice is removed and pavement is wet, slushy, or lightly snow covered when treated.

**Appendix M: Hamilton NJ Application Rates for Salt Brine**